

Being an Indispensable Presence in a Sustainable Society

Since our founding in 1924, PILLAR Corporation has offered products and services based on fluid control technologies and material technologies, contributing to the advancement of global society based on promoting a clean environment, safety, and frontier innovation. The markets for our innovative, high-quality products are wide-ranging and include semiconductors, energy, chemicals, automobiles, shipbuilding, civil engineering and construction, medical care and pharmaceuticals, and batteries.

We are focused on developing products, technologies, services, and manufacturing innovations that drive forward societal progress. We will continue to take on the challenge of remaining an essential driver of this progress through technological innovation in the

semiconductor market and through initiatives such as the pursuit of a carbon-neutral society.

Furthermore, we are strengthening our ESG initiatives and working to meet sustainable development goals so that we will be able to contribute to building a sustainable society throughout our corporate activities.

Taking guidance from our corporate principles—Quality First, Cooperation and Harmony, and Steady Research—we will work to enhance corporate value, contribute to a sustainable society, and further evolve as PILLAR Corporation.

Even beyond our 100th anniversary, we will remain an indispensable contributor to society as we continue to grow and innovate.



President

Y. Inami

Motto

**Quality
First**

**Cooperation and
Harmony**

**Steady
Research**

Purpose

Creating a future that supports society

CLEAN

SAFETY

FRONTIER

PILLAR CORE VALUES

Integrity	To maintain integrity and uphold high ethical standards in your professional conduct.
Innovation	To embrace the challenge of innovation to help create a better future society.
Progress	To pursue continuous improvement and reform to drive real evolution.
Human Resources	To use business activities to develop individuals who possess high levels of expertise, leadership, as well as social skills.
Team	To build a team where the wisdom and abilities of diverse colleagues generate synergy.

Group Code of Conduct

The Group Code of Conduct of PILLAR Corporation and its Group companies stipulates important action guidelines to which officers and company employees shall adhere in the conduct of their daily business activities. Employees have the essential obligation to take the initiative in adhering to this Code of Conduct.

Please refer to our website for details of the Group Code of Conduct
<https://www.pillar.co.jp/en/about/philosophy/>



With a corporate history exceeding 100 years, we have a record of contributing to the emergence of a sustainable and prosperous society through our expertise in fluid control.

For the more than 100 years since our founding, we have contributed to the emergence of a prosperous society committed to sustainability by demonstrating our expertise in fluid control. To achieve this, we have remained committed to meeting the needs of growth industries by becoming one of the first companies to focus on developing and commercializing innovative materials. Going forward, we will continue to provide original, high-quality products and services while further improving our fluid control technologies.

Business Growth

1924

Nippon Pillar Packing Industries is established in Nada-ku, Kobe.



Founder
Kaju Iwanami

1926

Our new factory is established in Yodogawa-ku, Osaka to begin full-scale production of industrial leak prevention packings.



1948

Nippon Pillar Packing Co., Ltd. is established.

1967

The Sanda Factory in Sanda City, Hyogo Prefecture, is completed.



1974

50th anniversary

1980

New head office building is completed.



1984

The Company's shares are listed as a specially designated share issue on the Second Section of the Osaka Securities Exchange.

1980

Korea Pillar Packing Co., Ltd. (currently PILLAR Korea Co., Ltd.) is established.

1989

Construction of the Fukuchiyama Factory (currently Fukuchiyama Factory No. 1) is completed in Fukuchiyama, Kyoto Prefecture.



1995

The Company's shares are redesignated to the Second Section of the Osaka Securities Exchange.

1993

Nippon Pillar Singapore Pte Ltd. (currently PILLAR Seal Solutions Singapore Pte Ltd.) as a sales hub for Southeast Asia is established.

1999

Nippon Pillar Corporation of America (currently PILLAR America Inc.) in the U.S.A. is established.

2001

The Company's shares are listed on the First Sections of the Tokyo Stock Exchange and Osaka Securities Exchange.

2004

Construction of the Kyushu Factory is completed in Koshi, Kumamoto Prefecture.

2001

Taiwan Pillar Industry Co., Ltd. (currently PILLAR Taiwan Co., Ltd.) in Taiwan is established.

2003

Suzhou Pillar Industry Co., Ltd. in China is established.

2007

Shanghai Pillar Trading Co., Ltd. (currently PILLAR Shanghai Co., Ltd.) in China is established.

2010

Nippon Pillar Packing Co., Ltd. Alger Liaison Office in Algeria is established.

2017

The head office is relocated to Nishi-ku, Osaka.

2015

Nippon Pillar (Thailand) Co., Ltd. (currently PILLAR Seal Solutions (Thailand) Co., Ltd.) in Thailand is established.
Nippon Pillar Middle East FZCO (currently PILLAR Middle East FZCO) in the UAE is established.

2016

NPK Fluid Control Systems Mexico S.A. de C.V. (currently PILLAR Seal Solutions Mexico S.A. de C.V.) in Mexico is established.

2018

Nippon Pillar Europe GmbH (currently PILLAR Europe GmbH) in Germany is established.

2020

Construction of the new Sanda Factory is completed.



2022

The Company's shares are moved to the Prime Market of the Tokyo Stock Exchange.

2023

TANKEN SEAL SEIKO CO., LTD. becomes a member of our Group.
Construction of Fukuchiyama Factory No. 2 is completed.
Construction of the R&D Center at the Sanda Factory is completed.

2019

PT. Nippon Pillar Manufacturing Indonesia (currently PT. PILLAR Manufacturing Indonesia) and PT. Nippon Pillar Indonesia (currently PT. PILLAR Seal Solutions Indonesia) in Indonesia are established.

A production facility in Nippon Pillar Corporation of America Houston Office (currently PILLAR America Inc. Houston Office) is added.

2024

To mark the Company's centennial, the Company is renamed PILLAR.

2020

Pillar Technology (Chuzhou) Co., Ltd. in China is established.

2021

Operation of Pillar Technology (Chuzhou) Co., Ltd. begins.

2023

Beijing Office of Shanghai Pillar Trading Co., Ltd. (currently PILLAR Shanghai Co., Ltd.) opens.

2025

New factory is completed for Pillar Technology (Chuzhou) Co., Ltd.

1920 Committed to development since our founding
Our DNA

1980 Expanding into the electronics sector
Business growth

2000 Strengthening our competitive advantage through ongoing business development
Drive competitive advantage

2020 Identifying market changes with the goal of sustainable growth
Toward next 100 years

1930

Our Pillar packing is registered as the Company's first utility model patent.

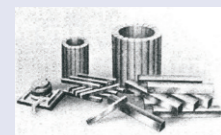

1932

Production of gaskets begins.



1951

The Company develops and begins production of Japan's first mechanical seal.

1952

Production of fluoro resin products begins. (Series name: PILAFLO™)

1969

It becomes the industry's first JIS-certified manufacturing facility for spiral-wound gaskets for piping compliant with the JIS B 2404 standard.

1970

The Company develops and begins production of carbonized fiber, an innovative new material.

1981

Production of ISO series mechanical seals for agitators begins.



1994

The Company begins production of Emission Defense Packing (EDP) to prevent permeation leakage through packings.

2002

The Company begins production of SUPER 300 TYPE PILLAR FITTING™, featuring a revolutionary sealing mechanism, an industry first.



2012

Production of new types of rotary unions for the semiconductor market begins.



2023

Production of the Pillar Sealant Circulating & Cooling System (PSCC) begins.



2025

The Company begins production of the EcoMAT™ electric power monitoring sensor incorporating a fluoro resin substrate.



Our founder, Kaju Iwanami, successfully developed a highly wear-resistant cylindrical packing for marine use and established the privately owned Nippon Pillar Packing Industries in 1924. In 1926, the Company began full-scale production of leak-proof industrial packings and, in 1932, it expanded its business to encompass gaskets for internal combustion engines used

in automotive and marine applications. In 1948, Nippon Pillar Packing Co., Ltd. was established, and in 1951, the Company developed and produced Japan's first mechanical seal. Construction of the Sanda Factory was completed in 1967, and a new head office building was constructed in 1980. The following year, production of ISO series mechanical seals began.

Since then, we have successively introduced fluoro resin fittings and expanded graphite braided packing for semiconductor manufacturing equipment, obtaining ISO certification in 1995. In 2002, we introduced the groundbreaking SUPER 300 TYPE PILLAR FITTING, the industry's first such sealing mechanism. The following year, we began production of Pillar Techno Black No. 2603-EEE, and since 2012, we have

been offering innovative types of rotary unions for the semiconductor industry. Following the completion of our new Sanda Factory in 2020, we have been transforming our business and organization in preparation for the development of next-generation products and the continued growth of this market. Our objective is to maintain sustainable growth that continues to add to our corporate value.

100 Years of Refining Expertise in Material Development and Extensive Fluid Control Solutions

PILLAR's Strengths ① Expertise in Material Development

During those 100 years, we have independently researched and developed materials that are suited to various conditions—for example, those of temperature, pressure, peripheral speed, and chemical resistance—in numerous different devices—for example, pumps, valves, and pipes. Our products, which include silicon carbide (SiC), expanded graphite, and fluororesin, are produced thanks to our exhaustive knowledge of material characteristics, and respond to a wide range of market and customer requirements. In the future, we will expand into new markets that include EV, hydrogen, and next-generation communications.

PILLAR'S Roots in Our Flagship Product, "PILLAR No. 1" Packing

Our founder, Kaju Iwanami, a former engineer on ocean-going vessels, recognized the need to develop a domestically produced gland packing offering minimal leakage. He did so in response to the problems encountered with foreign-made gland packings, which were of poor quality and frequently suffered from steam leaks. After much trial and error, he developed PILLAR No. 1, a cylindrical packing made of a wear-resistant alloy. This innovation contributed to increased safety and improved working conditions.

Our passion for material development as well as our evidence-based approach have become part of our DNA since our founding. They represent the very foundation of our strengths and expertise in material development.

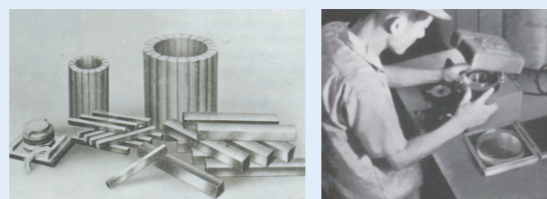

Fluororesin Products

Fluid control technology for hazardous chemicals

PILAFLO is our general brand of practical products incorporating PTFE. These products take advantage of this material's excellent resistance to heat and chemicals as well as its non-stick properties, which contribute to excellent fluid control in gaskets, bearings, and other sealing products. We also handle PFA, a material ideal for molding into complex shapes by means of hot melt molding. Moreover, we use our knowledge of fluororesins to develop fittings for use in the semiconductor sector.



Fluororesin

Carbon Fiber

Pioneering research that meets the challenge of asbestos replacement

We have been conducting research into alternative materials since before asbestos was recognized as a material hazardous to human health. For example, we developed the No. 6501L Gland Packing, which incorporates a carbonized material that combines outstanding hardness with self-lubrication properties. It has maintained top sales among products used for water and seawater applications as an asbestos-free material that withstands high rotational speeds and causes minimal shaft wear. The technology has been adopted for successor products of carbon and carbonized materials.



Gland Packing (No. 6501L)

Silicon Carbide

Research on sliding materials for high-load environments

We use Silicon Carbide (SiC), a material with high thermal conductivity and a hardness second only to diamond, as a sliding material. Our in-house integrated SiC production line handles all processes from raw material mixing to grinding and polishing. The resulting material is stable even when exposed to strong acids and alkalis and is used in a wide range of industries, including shipbuilding, power generation, steelmaking, and chemicals and petrochemicals. This material is also incorporated into a wide range of other products, including mechanical seals.



SiC sliding material

Expanded Graphite

An innovative material born from the need to comply with environmental regulations

Expanded graphite exhibits stable sealing performance even in environments of high temperature and pressure. As well, it has been used in plants where use of conventional asbestos packing has become difficult. We have established a technology to process expanded graphite, which was previously only available in sheet form, into a thread form as yarn, which has accelerated the shift to completely asbestos-free products. We have thus created a new business model centered on environment-friendly products.



Gland Packing (EDP15)

Since its founding in 1924, PILLAR has prospered alongside the flourishing of Japanese industry, developing products that anticipate emerging needs.

PILLAR's advantage lies in its expertise in material development and extensive fluid control solutions.

Through our consistent research and development efforts, we have gained a comprehensive understanding of the properties of a wide variety of materials.

PILLAR's Strengths ② Extensive Fluid Control Solutions

In line with customer needs, we are combining our know-how as a Group to provide technologies, products, and services that only PILLAR can achieve. For example, in the field of fluororesin products, for forms that were ordinarily created using a cutting process, we switched to injection molding, thereby realizing shorter lead times and improved production volumes. With proposals that leverage a technological track record that is characteristic of a comprehensive manufacturer of seals, we are also responding precisely to customer needs in the field of seals for industrial equipment.

From Sea to Land

Gasket development

In 1932, we employed our marine technology to the development of metal-jacketed gaskets for use in automobile engines. Their quality has been recognized as important components for preventing the leakage of explosive gases, and they were adopted as manufacturer-certified parts. Expanding into the petroleum refining and chemical sectors, we introduced high-performance, asbestos-free gaskets in 2003 to meet environmental regulations, which resulted in a further increase in demand.



Serving the Petrochemical Industry

Development of Japan's first mechanical seal

In 1951, in response to the growing need for reduced leaks, we developed Japan's first mechanical seal. This product was widely adopted for pumps in the power generation industry and in the chemical and petrochemical sectors. We continue to develop products to meet diverse needs while maintaining our position as a leader in our industry.



Serving the Semiconductor Industry

Fluororesin fittings for chemical piping

In 1984, we entered the semiconductor market by introducing our Pillar Fitting made of fluororesin. In 1988, we developed the Super Type Fitting. This was followed by the SUPER 300 TYPE PILLAR FITTING, which adopted an interference-fit seal structure offering improved performance and ease of installation. After earning a great deal of trust from the semiconductor sector, we have succeeded in securing the leading share of the global semiconductor cleaning equipment market.

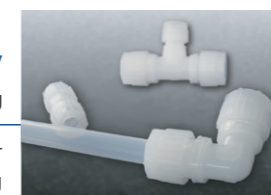

Serving the Construction Industry

Leveraging our expertise in fluororesins

In 2001, we developed the Rigid Sliding Bearing, which adapts existing sliding bearings for seismically isolated structures. For this product, we succeeded in obtaining certification from Japan's Minister of Land, Infrastructure, Transport and Tourism. Incorporating a sliding material made from fluororesin, this bearing achieves one of the industry's lowest coefficients of friction. It has been adopted in high-rise housing, semiconductor plants, and other such structures.



Serving the Medical Industry

Continued development of new markets

To address the challenges of heat resistance and age-related degradation of PVC tubing used in dialysis, we introduced perfluoroalkoxy alkane (PFA) tubes, which have a proven track record in the semiconductor field, together with SUPER 300 TYPE PILLAR FITTING products. This combination has overcome these challenges while also improving cleanliness and chemical resistance. After their launch in 2010 along with our installation guidance service, these products gained the confidence of the market, resulting in their widespread adoption. They became established in clinics seeking such advanced features, a development that served as a launchpad for the emergence of new applications.



The Ongoing Evolution of PILLAR

Through the initiatives outlined above, we have been able to manufacture products of ever higher quality by producing everything we need in-house, from the raw materials onwards, and by maintaining consistency in our internal production processes. We value the technical expertise that enables us to continue meeting customer needs, an asset that we have built on throughout the 100 years since our founding. We pledge to continue honing our production technologies and promoting research and development as we work to fulfill the emerging needs of the marketplace.

Earning Trust by Serving Every Market with Advanced Technologies

PILLAR continues to perfect its renowned fluid control technologies. Products incorporating our expertise are now being used in a variety of industries even outside the field of fluid control. As we continue to focus on refining our quality, we are spreading greater safety and security to even more segments of the global market.

PILAFLON™

This product reflects the low friction, chemical resistance, and weather resistance of fluororesin, which exhibits a chemically stable nature that makes it resistant to acidic and alkaline substances. These properties make it essential for use in advanced industries related to the semiconductor, LCD, construction, and information and communications sectors. PILAFLON has grown alongside the semiconductor market to become PILLAR's flagship product.

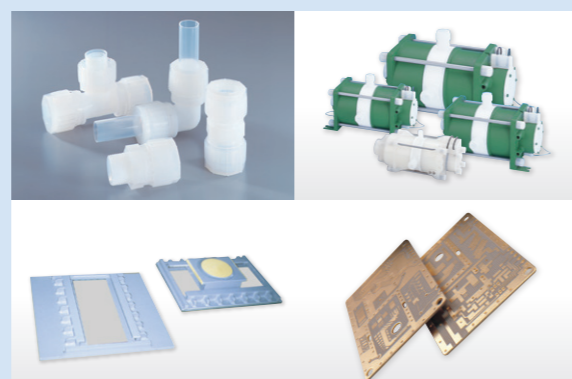

PILAFLON™

PILAFLON is our registered trademark for a group of products made from fluororesins. We meet a range of needs in industries ranging from semiconductors and LCDs to civil engineering, construction, and information and communications.



SUPER 300 TYPE PILLAR FITTING™ Products

These fittings can be used with both acidic and alkaline chemical solutions. Because cleanliness is essential in many of the industries we serve, we manufacture our products in a strictly controlled "clean room" environment.

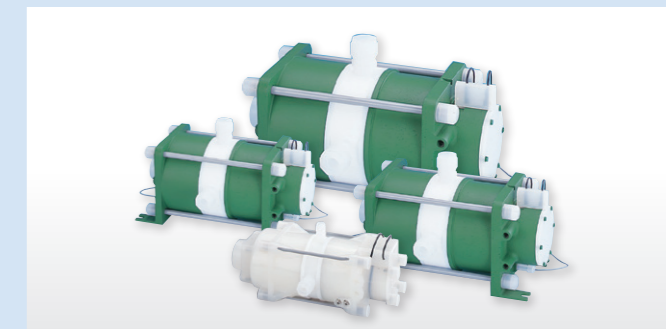

SPELA™ 300 Bellows Pumps

The pump itself achieves low pulsation pressure, ensuring smooth liquid flow. Various models are available for specific operating temperatures, sizes, and other factors, ensuring their compatibility with a wide range of equipment.

Mechanical Seals

Developed in 1951, these exceptionally airtight products are used to control highly hazardous fluids. They are widely used in applications as diverse as petroleum refining, chemical manufacturing, papermaking, steelmaking, food processing, shipping, and water supply and sewerage. Thanks to their excellent stability, they comply with JIS and ISO standards.



Fluid Control Equipment Series

We also offer a series of products that include metering pumps with high discharge accuracy and various manual valves made from fluororesin.

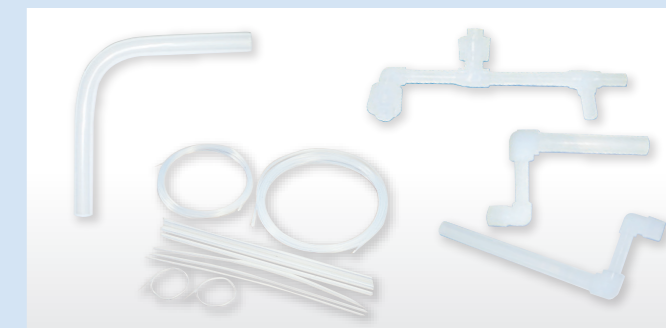

Welded and Bent Tube Piping (PFA Tubes)

Welded and bent tube piping made from perfluoroalkoxy alkane (PFA) tubes takes advantage of the excellent heat resistance and electrical properties of this fluororesin material. This product is used in the semiconductor industry and in many other industries.

Gland Packings / Gaskets

Starting with PILLAR's first product, a cylindrical packing for marine vessels, these products employ fluid control technology to prevent leaks. The sealing technology we have continued to refine is utilized in pipe and equipment joints as well as in the moving parts of valves and pumps.

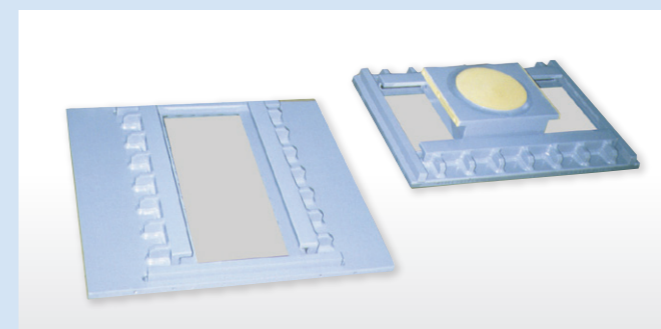

UNI-TON™ Bearing System

Rotating and sliding mechanisms are designed to reduce and absorb the seismic forces acting on supports in seismically isolated buildings, roofs, and connecting bridges.

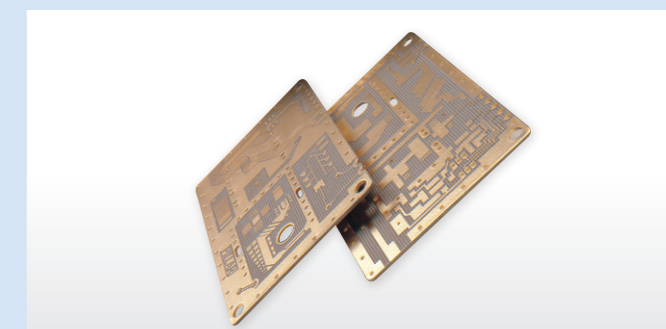

PILLAR PC-CLAD™

Developed with excellent coating technology, this fluororesin substrate is suitable for high-frequency applications. It is widely used in antennas for various radars and in communication base stations.

Mechanical Seals

These shaft seal devices for rotating machinery comprise two components: a sliding ring that moves axially by means of a spring or other means; and a stationary sliding ring. The surfaces of the sliding rings come into contact with each other to control fluid leakage.



Split Seals

These mechanical seals are used in large pumps that draw in water from rivers and other such sources. Because the sliding parts on the fixed and rotating sides are separate, maintenance is simplified.



Non-Contact Dry Gas Seals

These non-contact gas seals are used in equipment that handles gases that cannot be permitted to leak to the atmosphere. These include toxic and flammable gases, as well as gases containing powder.



Porous Carbon

This porous carbon product features adjustable fluid permeability and is used in a variety of applications, including vacuum suction cups for semiconductor wafers and floating transport of high-performance films.

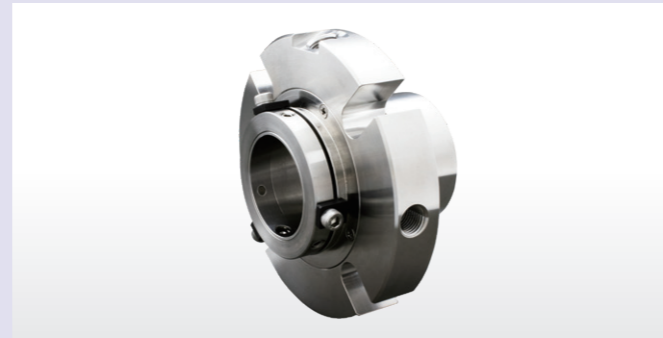

Cartridge Mechanical Seals

These are general-purpose mechanical seals in cartridge form that are easy to handle and can be used for a wide range of fluids, from clean water to high-viscosity liquids and gel-like fluids.



PILLAR SUPER JOINT™ Products (Mechanical seals for rotary unions)

These rotary unions employ mechanical seals to transfer and supply fluids and gases between rotating and fixed parts. They are used in a wide range of markets, including general industry as well as in chemical mechanical polishing (CMP) processes used with semiconductor manufacturing equipment.

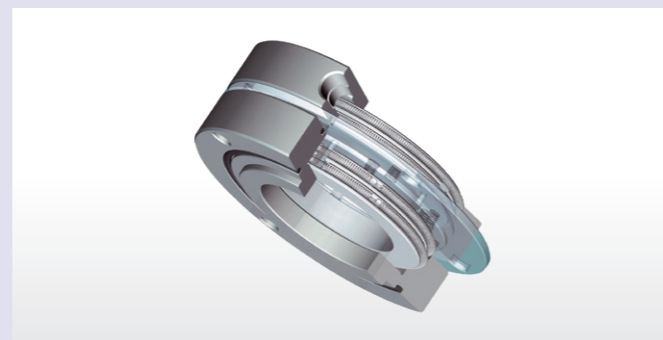

ABC Seal Products

These shaft seals incorporate a split-type carbon/PTFE sliding material that is easy to disassemble and reassemble. It has a proven track record in blowers and in powder-handling equipment such as rotary valves.

Gland Packings / Gaskets

Gland Packings

“Gland packing” is the general term for packings that typically have a rectangular cross section and are packed into stuffing boxes. These packings are used to seal the shafts in valves, pumps, and other rotating or reciprocating machinery.

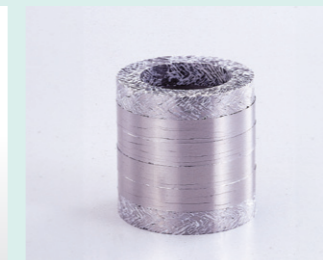

PILLARFOIL™ Packing Series

PILLARFOIL is the registered trademark for our expanded graphite product group. PILLARFOIL packings are world-leading products that combine long life and high reliability. Thanks to their excellent properties, they have been used successfully in numerous high-temperature and high-pressure applications.

Asbestos-Free Gland Packings

To meet market demand, we offer a line of products made from a variety of materials, including carbon fiber, carbonized fiber, PTFE fiber, and aramid fiber. Among these, Pillar No. 6501L, which incorporates carbonized fiber, has become synonymous with general-purpose asbestos-free products in terms of performance and ease of handling. Since its introduction, it has been our top-selling gland packing for rotating machinery.

Gaskets

“Gasket” is the general term for seals used to seal stationary parts, such as pipes and equipment joints. In light of their reliability and proven technical capabilities, they are used in a wide range of industrial sites, including nuclear power plants, oil refineries, and petrochemical complexes.

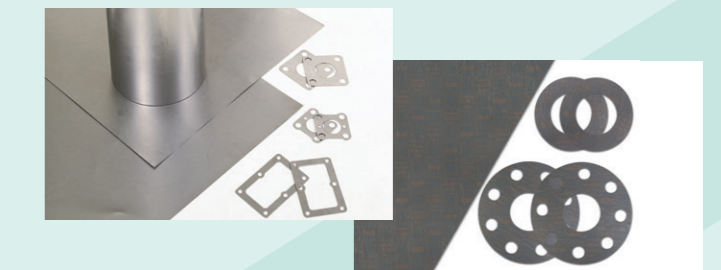
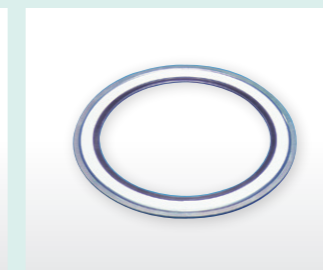
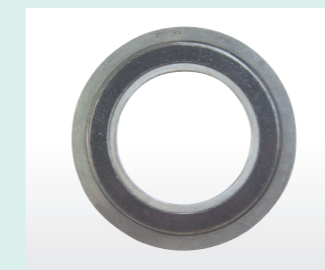

Spiral-Wound Gaskets

By modifying the composition of these gaskets, we can accommodate the particular fluid being used. This approach enables us to offer highly reliable gaskets that provide excellent sealing performance under a wide range of conditions.

Asbestos-Free Sheet Gaskets

Our series of asbestos-free sheet gaskets offer excellent resistance to heat and chemicals, making them suitable for a wide range of fluids.

Contributing to the Safety and Security of Society and the Environment Through the Control of a Wide Range of Fluids

We are a manufacturer skilled in the design, development, and manufacture of equipment to control fluids such as water, oil, toxic gases and chemicals, and more. Our products are used in facilities that are essential to the functioning of daily life. Moreover, they contribute to environmental preservation, resource conservation, and the protection of lives and property.

Main devices supplied

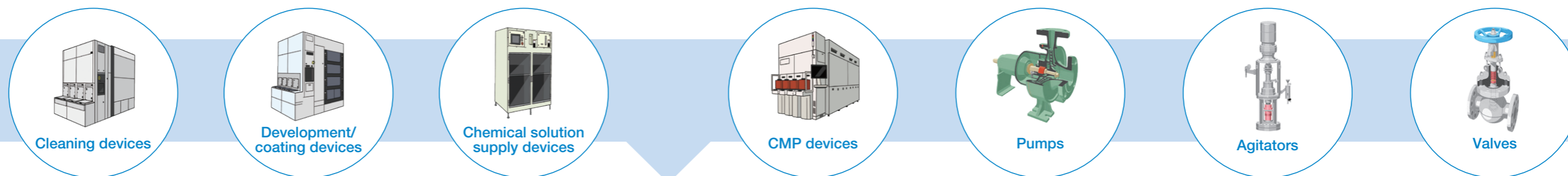

Main supply destinations

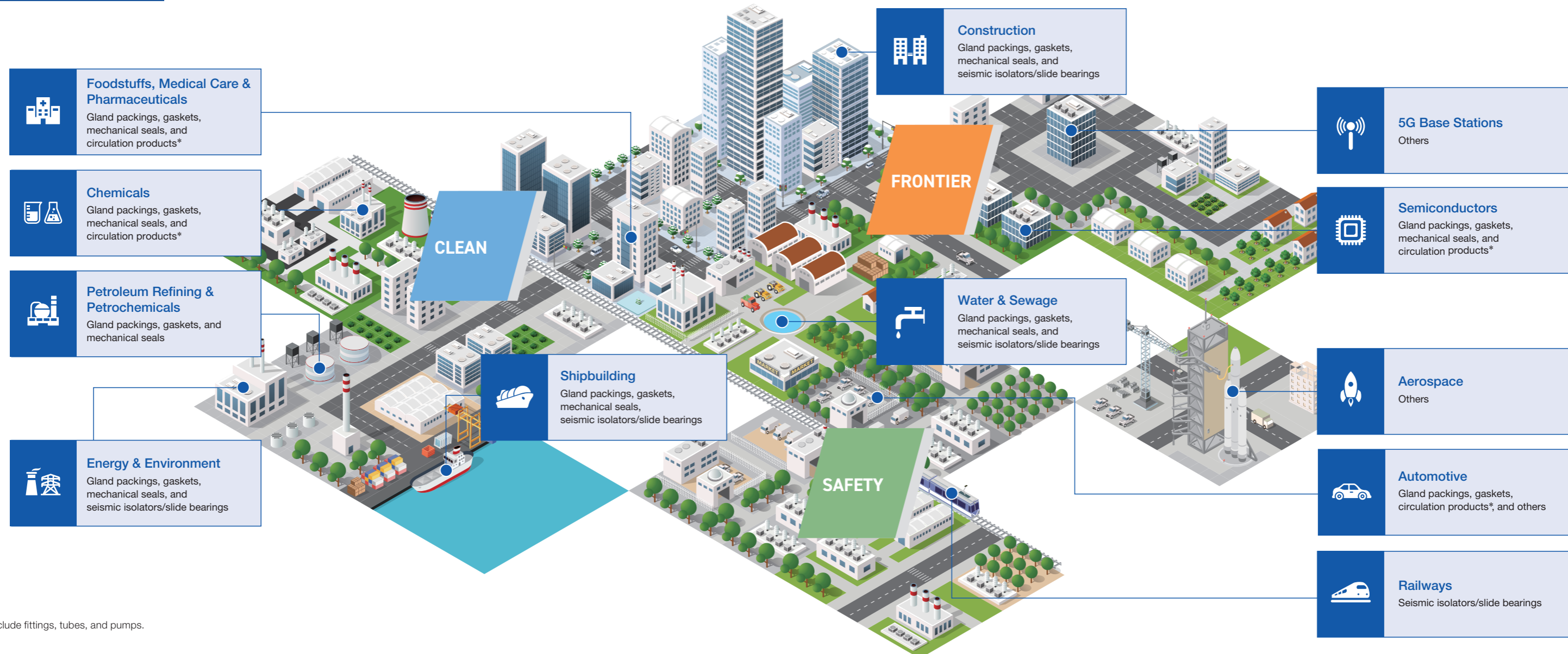

*Include fittings, tubes, and pumps.

Achieving Our Purpose by Underpinning the Foundational Technologies That Drive the Evolution of Our Core Technologies

With the evolution of our core technologies and the increasing sophistication of our fundamental technologies—all of which are focused on our key concepts of “Clean, Safety, and Frontier”—we are creating unique value by building on the digital transformation as we remain committed to our goal of “Creating a future that supports society.”

PILLAR Corporation’s Core Technologies and R&D Concepts

Since our founding, we have employed our fluid control technology and material development capabilities to explore previously unknown materials and conduct research and development of the latest technologies, thereby creating value and developing applications that reflect market trends and address societal issues.

Engineers Assembled at the Sanda Factory’s R&D Center

In October 2023, we opened our R&D Center within the Sanda Factory; in November 2024 we consolidated the Technical Departments from Fukuchiyama within this Center. This R&D Center is positioned as a hub for spurring innovation and strengthening our technological expertise through the combination and fusion of our proprietary technologies while enhancing collaboration among industry, government, and academia in the area of product development. We remain focused on generating new ideas and creating value through this initiative.



Collaborative Development with TANKEN SEAL SEIKO

As one of the synergies derived from the incorporation of TANKEN SEAL SEIKO’s technologies, we are promoting collaborative innovation and are developing highly functional new products that fuse the strengths of both companies in the form of carbon technology and noncontact sealing technology.

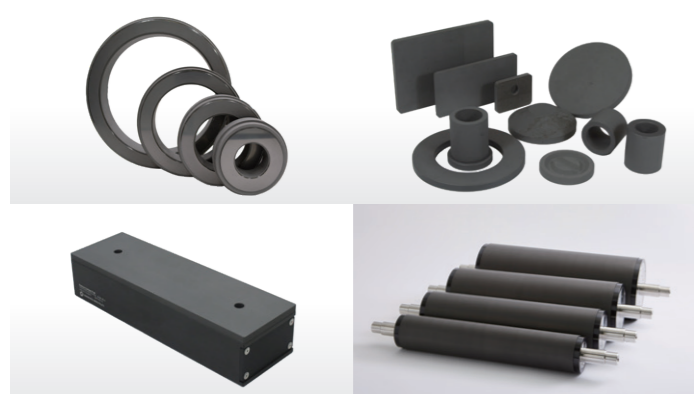

Analysis and Testing Equipment

As the owner of many patented products, we conduct a number of experiments under actual operating conditions before introducing our products to society. Our research and development, supported by the latest verification technologies, continues to evolve toward even higher goals.

Microscopic Analysis Technology

In order to meet the ever more stringent cleanliness requirements associated with the increasing miniaturization of semiconductors, we are building a system capable of performing multifaceted analysis of both organic and inorganic substances.



Inductively Coupled Plasma Mass Spectrometer (ICP-MS/MS)



Gas Chromatography-Mass Spectrometer (GC-MS)



Total Organic Carbon (TOC) Analyzer

Data Collection and Analysis Test Equipment for Failure Prediction

This test equipment is used to collect and analyze data on pressure, temperature, torque, vibration, etc. under operating conditions, including failure modes, in order to establish technology for predicting mechanical seal failures.

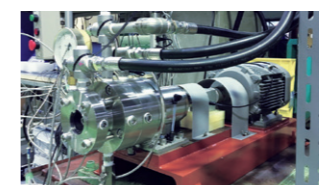
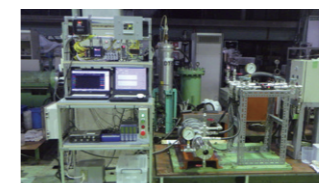

X-ray Photoelectron Spectroscope (XPS)

This analytical device can determine the bonding state of atoms and molecules on and below the surface of a material. This innovation helps to elucidate the tribology, or unique wear phenomena, of sealing products for the hydrogen market.



Test Equipment for Semiconductor and Liquid Crystal Manufacturing Devices

To evaluate performance under the harsh operating conditions that exist in the semiconductor fabrication industry, we utilize thermal cycle test equipment capable of cycling between high and low temperatures.



1000 kN Universal Testing Equipment

The device is capable of performing sealing, compression, and tensile tests while precisely controlling the load on products and materials. With 24-hour continuous operation possible, continuous data can be obtained on changes that occur over time.



Resin Flow Analysis

We employ resin flow analysis to design optimal molds by predicting the potential for molding defects. This helps reduce the number of mold modifications while maintaining or improving product quality.

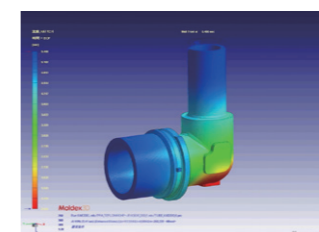

Hydrogen Atmosphere Friction and Wear Testing Machine

We have introduced testing equipment and analytical instruments capable of evaluating materials within a hydrogen atmosphere. Such innovations advance our understanding of tribochemical reactions in sliding components as we focus on improving our development of products and materials.



The PILLAR GROUP is operating in 12 countries and regions around the world, including Japan.

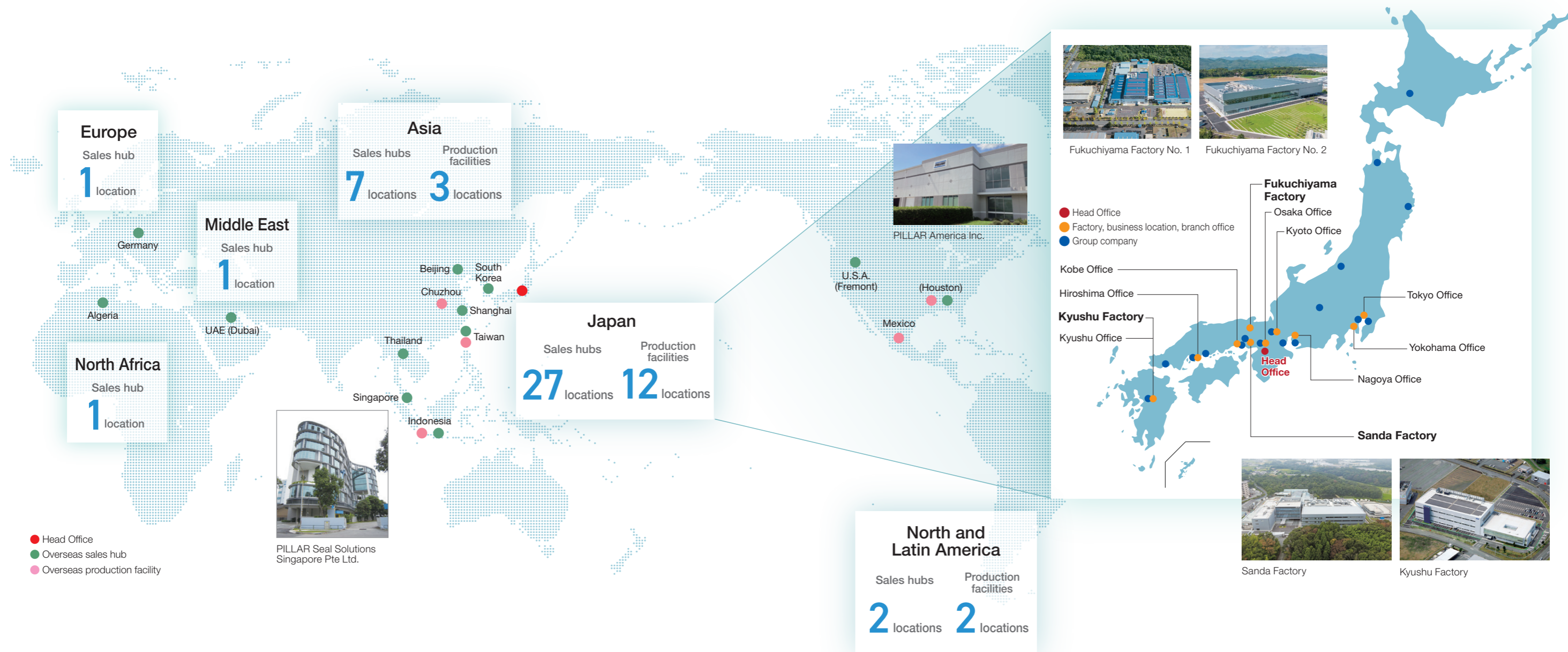

List of overseas sites

PILLAR Taiwan Co., Ltd. Taipei Office
 PILLAR Taiwan Co., Ltd. Takao Factory
 PILLAR Shanghai Co., Ltd.
 PILLAR Shanghai Co., Ltd. Beijing Office
 Pillar Technology (Chuzhou) Co., Ltd.
 PILLAR Seal Solutions Singapore Pte Ltd.

PT. PILLAR Seal Solutions Indonesia
 PT. PILLAR Manufacturing Indonesia
 PILLAR Seal Solutions (Thailand) Co., Ltd.
 PILLAR Korea Co., Ltd.
 PILLAR Seal Solutions Middle East FZCO
 PILLAR Europe GmbH

PILLAR America Inc. Houston Office
 PILLAR America Inc. Fremont Office
 PILLAR Seal Solutions Mexico S.A. de C.V.
 Nippon Pillar Packing Co., Ltd. Alger Liaison Office

List of domestic sites

[Factories and business locations]
 Sanda Factory (Sanda City, Hyogo Prefecture)
 Fukuchiyama Factory No. 1 and No. 2 (Fukuchiyama City, Kyoto Prefecture)
 Kyushu Factory (Koshi City, Kumamoto Prefecture)

[Branch offices]
 Tokyo Office, Osaka Office, Yokohama Office, Kobe Office, Nagoya Office, Hiroshima Office, Kyoto Office, Kyushu Office

[Domestic Group companies]
 TANKEN SEAL SEIKO CO., LTD., PILLAR Seal Solutions Corporation, PILLAR Precision Corporation, NP Kogyo Corporation, NP Sangyo Corporation, NP Real Estate Corporation, PILLAR Kyushu Corporation, Masuko Manufacturing Corporation

Company Profile (As of March 31, 2025)

Company name	PILLAR Corporation
Head Office address	7-1, Shinmachi 1-chome, Nishi-ku, Osaka 550-0013, Japan
Establishment	1924
Representative	Yoshinobu Iwanami, President
Capital	¥4,966 million
Listed stock exchange	Tokyo Stock Exchange Prime Market
Main products	PILAFILON products (fluorocarbon polymers products), mechanical seal products, gland packings and gasket products
URL	https://www.pillar.co.jp/en/

External Evaluations

ISO Certification

In 1995, the Group became the first domestic seal manufacturer to obtain ISO 9001 certification for its quality management system. The current certifying body is the Japan Quality Assurance Organization, while accreditation is provided by JAB (in Japan) and UKAS (the UK). The head office and the Sanda and Fukuchiyama Factories have obtained ISO 9001 certification.



IATF Certification

In 2019, products for automotive use produced at the following factory have obtained IATF 16949 certification, an international quality management system standard for the automobile industry. IATF 16949 was developed by Western automobile manufacturers and automobile industry-related organizations to prevent defects, reduce inconsistency and waste in the supply chain, and bring about continuous improvement by standardizing requirements for parts manufacturers. Based on ISO 9001, this quality management system incorporates a large number of unique requirements.



Registered site: PILLAR Corporation Sanda Factory
 Scope of certification: Design and manufacturing of gaskets, packings, exhaust system molded products, and fluorocarbon resin substrate

ESG-Related External Assessments

We have been assessed by an externally based ESG evaluation organization and have been selected as a member of the ESG Index.



Declaration of Partnership Building

The PILLAR GROUP has endorsed the aims of the Future Partnership Building Promotion Council, and in May 2024, we announced our participation in the Declaration of Partnership Building, which is promoted by the Cabinet Office, the Ministry of Economy, Trade and Industry, and the Small and Medium Enterprise Agency.



Advancing the leading edge to protect
 the planet and keep manufacturing safely flowing.

