



**PILLAR**

# CORPORATE PROFILE



# Fluid Control Technol

## Committed to Helping Local Communities Develop, and Delivering Value to Our Customers

We will respond swiftly to changes in the business climate and bring about market and social development through our ability to see beyond the changes and take bold action.

And as a good corporate citizen, we are committed to contributing to the development of local communities and continuing to provide products that make our customers happy.



# Technology & People



## CONTENTS

- 1 What We Value
- 2 Contents
- 3 Corporate Principles and Management Philosophy
- 4 Message from the President
- 5 Our Mission
- 9 A Record of Growth
- 11 Mother Factories that Underpin Our Business
- 13 R&D
- 15 Group Network
- 17 Segment Overview
- 21 External Evaluations and Activities
- 22 Company Information

**Corporate  
Principles**

**Quality First / Cooperation and Harmony / Steady Research**

**Management  
Philosophy**

- 1** To contribute to the creation of a world that is pleasant to live in, with an affluent social climate.
- 2** To offer original, high-quality products, and strive to be a company that is essential to customers.
- 3** To comply with legal and social norms, and engage in proper, sound business practices.

## Being an Indispensable Presence in a Sustainable Society



Since our founding in 1924, Nippon Pillar Packing Co., Ltd. has offered products and services based on fluid control technologies and material technologies, contributing to the advancement of global society based on promoting a clean environment, safety, and frontier innovation. The markets for our innovative, high-quality products are wide-ranging and include semiconductors, energy, chemicals, automobiles, shipbuilding, civil engineering and construction, medical care and pharmaceuticals, and batteries.

We are focused on the development of technologies, products, services, and production technologies, and will continue striving to maintain an indispensable presence in a global society that is advancing through technological innovations in the semiconductor market and initiatives such as efforts to achieve carbon neutrality.

Furthermore, we are strengthening our ESG initiatives and working to meet sustainable development goals so that we will be able to contribute to building a sustainable society throughout our corporate activities.

Taking guidance from our corporate principles—Quality First, Cooperation and Harmony, and Steady Research—we will work to enhance corporate value, contribute to a sustainable society, and further evolve as Nippon Pillar Packing Co., Ltd.

Even beyond our 100th anniversary, we will continue to innovate, grow, and strive to be an indispensable presence in society.

## Creating a Future That Supports Society Creating New Value towards a Sustainable Society

Nippon Pillar Packing will create unique value based on the principles of CLEAN, SAFETY, and FRONTIER, and will strive for new possibilities.

### CLEAN

#### Achieving a clean global environment

Controlling fluids helps to conserve energy and resources, leading to a clean global environment.

Nippon Pillar Packing contributes to this endeavor by using its technology to control fluids for semiconductor and LCD manufacturing equipment and for major industrial equipment.

### SAFETY

#### Contributing to a safe and secure society

Safety takes precedence over everything else when it comes to improving the quality of work and keeping our workforce energized.

Controlling fluids helps to control flammable, toxic, and other harmful fluids in a consistent, regular, and precise manner.

Nippon Pillar Packing contributes to a safe and secure society with our fluid control technologies.

### FRONTIER

#### Expanding into new fields that develop the leading edge of the industry

Since our founding, Nippon Pillar Packing has produced original, high-quality products through research and development always one step ahead of our competitors.

Nippon Pillar Packing will continue to take up the challenge of pioneering cutting-edge fluid control technologies and new fields of business.

## Electronic Equipment Business

¥36,819 million  
75.6 %

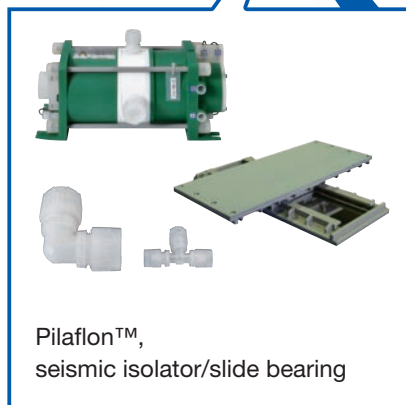
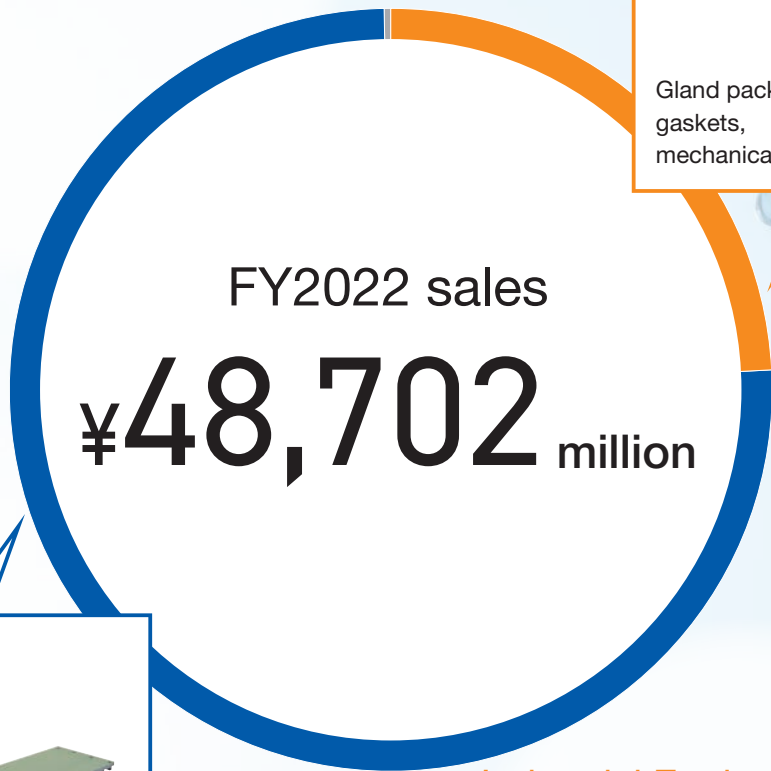

## Industrial Equipment Business

¥11,844 million  
24.3 %

### Electronic Equipment Business

We are specialists in the high-tech sector, especially in the semiconductor, LCDs, and medical sectors. In particular, we offer fittings, pumps and other components made from fluororesin, which offer high chemical resistance, heat-resistance, and cleanliness. Because they are unaffected by various chemical solutions, these products are ideal for use in silicon wafer cleaning systems.

### Industrial Equipment Business

We handle mainly mechanical seal products that control fluids in rotating equipment such as centrifugal pumps that transfer fluids, gland packing products used as sealing materials for valve stem components, and gasket products used for mating pipes.

# Contributing to the Safety and Security of Society and the Environment through the Control of a Wide Range of Fluids

We are a manufacturer skilled in the design, development, and manufacture of equipment to control fluids such as water, oil, toxic gases and chemicals, and more.

Our products are used in facilities that are essential to the functioning of daily life.

Moreover, they contribute to environmental preservation, resource conservation, and the protection of lives and property.

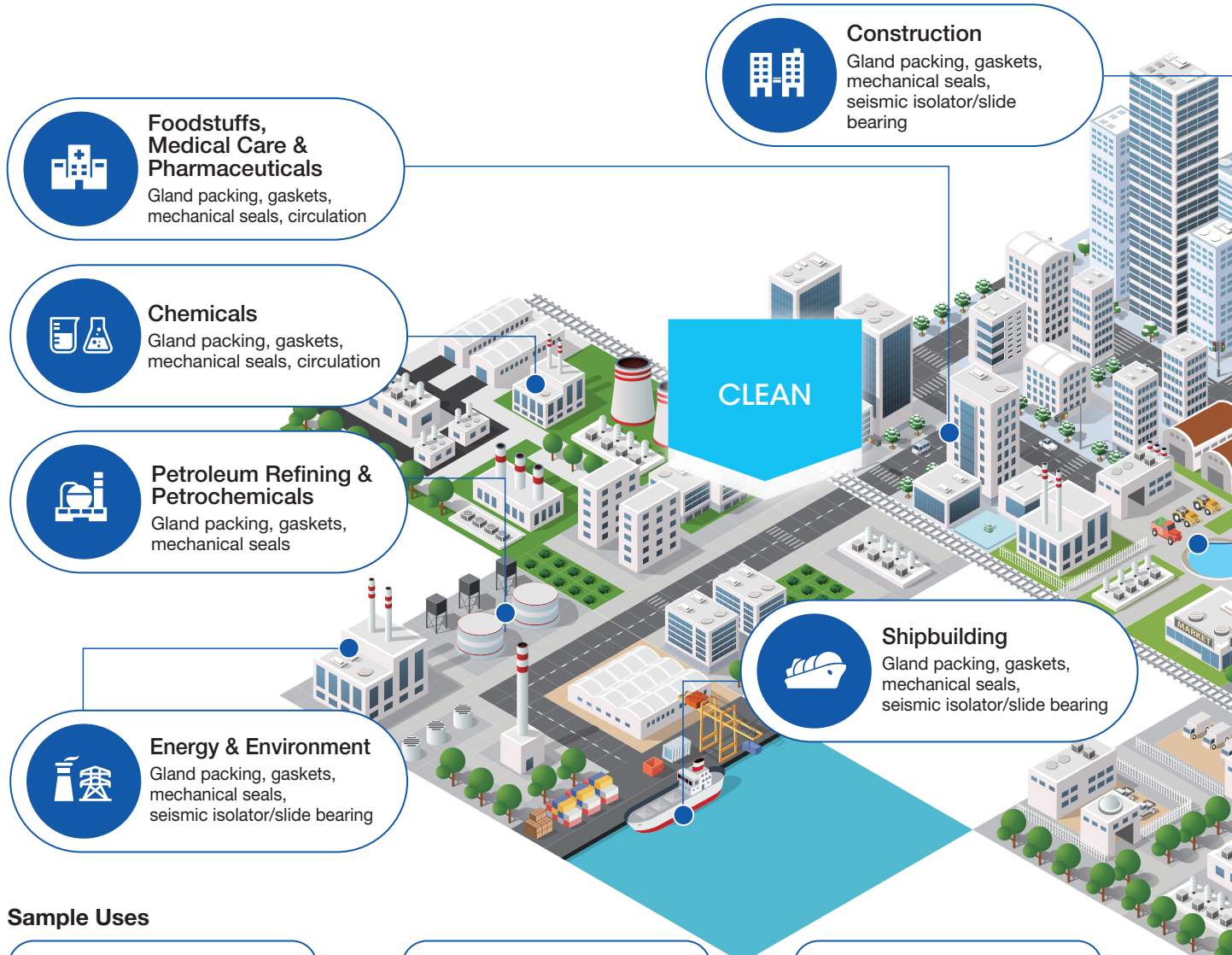

## Sample Uses

Semiconductor cleaning equipment



Circulation

Structure fitted with seismic isolators

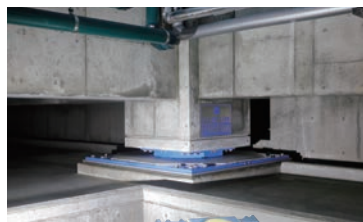

Seismic isolator / Slide bearing

Fluororesin substrates for high-frequency

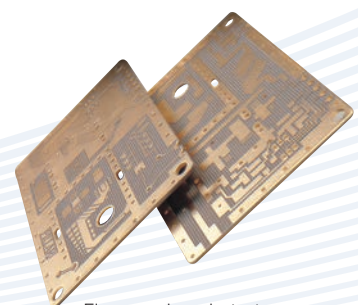

Fluororesin substrates for high-frequency



**Sample Uses**



**Valves**

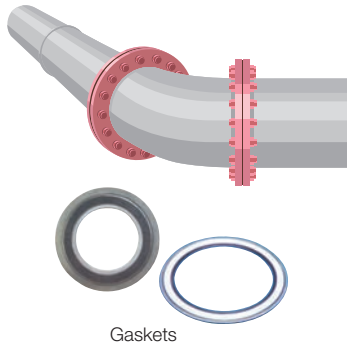

**Pipes**

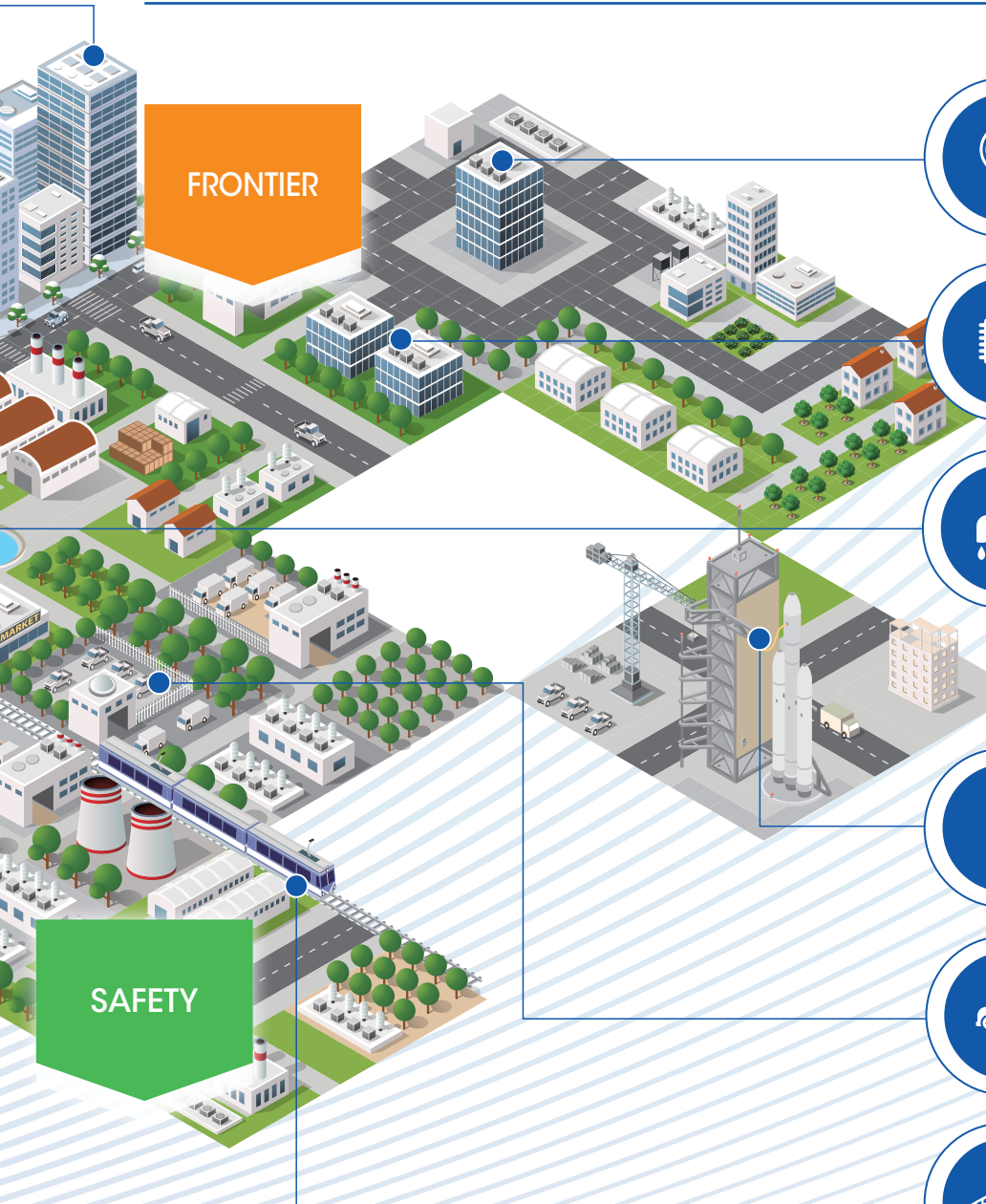
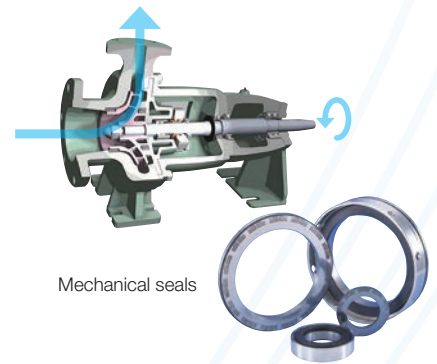

**Pumps**

**5G Base Stations**  
Others



**Semiconductors**  
Gland packing, gaskets, mechanical seals, circulation



**Water & Sewage**  
Gland packing, gaskets, mechanical seals, seismic isolator/slide bearing



**Aerospace**  
Others



**Automotive**  
Gland packing, gaskets, circulation, others



**Railways**  
Seismic isolator/slide bearing

Note: Circulation means products for the clean market

# Meeting Current Needs by Developing Products That Create Value

For over 95 years since its founding, Nippon Pillar Packing has worked to serve the needs of growing industries by quickly utilizing new materials in order to commercialize new products and thereby contribute to the realization of a prosperous, sustainable society.

Going forward, we will continue to provide original, high-quality products and services while further improving of our fluid control technologies.

## 1920

### From our founding to the establishment of our production system

Main needs: Shipbuilding

Company founder Kaju Iwanami, who was trained as an engineer, succeeded in developing a highly wear-resistant cylindrical packing for use in ships. The history of the Company began in 1924 when Nippon Pillar Packing Industries started as a privately held company with a factory on the site of a former stable in what is now Nada-ku, Kobe. In 1926, the Company established a new factory in Yodogawa-ku, Osaka City, to undertake full-scale production of industrial-use sealing packings. In 1930, our pillar packing was registered as the company's first utility model patent, and in 1932 the Company began producing gaskets for automobiles and marine engines.

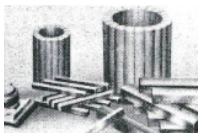

Patented Pillar Packing No. 1



Founder Kaju Iwanami

## 1940

### Technological breakthroughs

Main needs: Energy

In 1948, Nippon Pillar Packing Co., Ltd. was established and the Tokyo Branch Office (currently the Tokyo Branch) was opened. In 1951, the Company developed and started production of the first mechanical seal in Japan. The following year, it developed vertical gaskets for high-temperature, high-pressure pipe flanges and started production of fluororesin products.

The Sanda Factory, completed in 1967 in Sanda, Hyogo Prefecture, became the industry's first JIS-certified factory for spiral-wound gaskets for JIS B 2404 piping.

In 1970, the Company developed and started production of carbonized fiber.



Developed and started production of Japan's first mechanical seal (1951)



Construction of the Sanda Factory in Sanda, Hyogo, Japan (1967)

## 1980

### Establishment of our brand and global expansion

Main needs: Automotive

In 1980, the head office building was constructed. Production of ISO series mechanical seals began the following year. In 1984, the Company's shares were listed as a specially designated share issue on the Second Section of the Osaka Securities Exchange. The Company developed a series of new products to meet emerging needs and, in quick succession, started production of fluororesin fittings and expanded graphite braided packing for semiconductor manufacturing equipment. In 1989, the Fukuchiyama Factory (currently the Fukuchiyama Office) was completed in Fukuchiyama, Kyoto Prefecture.

In 1995, the Company's shares were listed on the Second Section of the Osaka Securities Exchange. The Company acquired ISO certifications and is committed to establishing a brand that warrants the confidence of its customers.



Started production of ISO series mechanical seals for agitators (1981)



Construction of the Fukuchiyama Factory (currently Fukuchiyama Office) in Fukuchiyama, Kyoto Prefecture, Japan (1989)

**1924** Nippon Pillar Packing Industries is established.

**1926** Full-scale production of industrial leak prevention packings begins.

**1932** Production of gaskets begins.

**1989** The Fukuchiyama Factory (currently the Fukuchiyama Office) is completed.

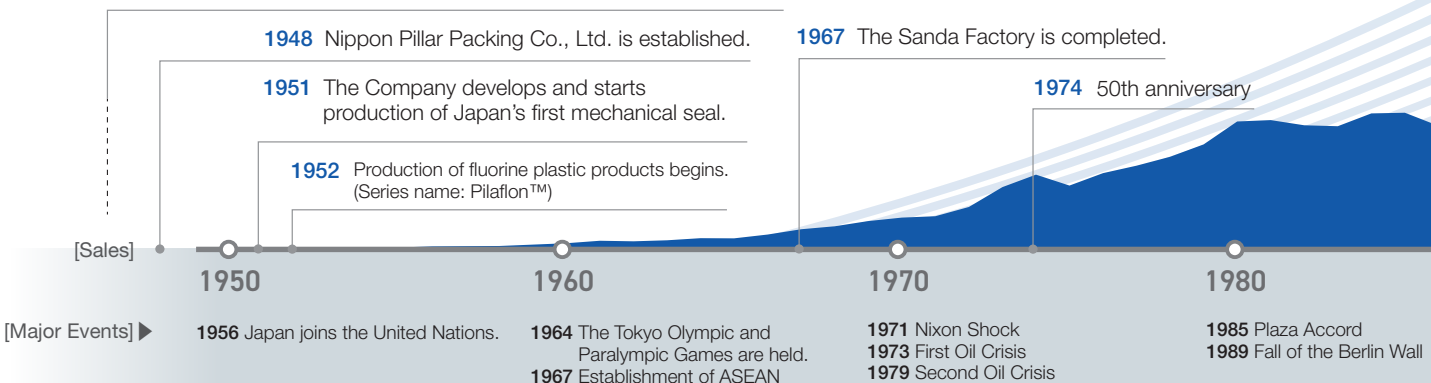

## 2000

### Developing new businesses that lead to ongoing breakthroughs

Main needs: Semiconductors

In 2001, the Company's shares were listed on the First Section of the Tokyo Stock Exchange and the Osaka Securities Exchange. In 2002, the Company began production of the Super 300 Type Pillar Fitting, a groundbreaking sealing mechanism that represented an industry first. The following year saw the start of production of Pillar Techno Black No. 2603-EEE, which contributed to the early conversion to asbestos-free sealing products. In 2004, the Kyushu Factory was completed in Koshi, Kumamoto Prefecture. In 2012, production of a novel type of rotary joint for the semiconductor industry began. In 2017, the head office was relocated to Nishi-ku, Osaka.



Began production of Super 300 Type Pillar Fitting with a revolutionary sealing mechanism, the first of its kind in the world (2002)



Construction of the Kyushu Factory in Koshi, Kumamoto Prefecture, Japan (2004)

## 2020

### Identifying market changes with the goal of sustainable growth

Main needs: Decarbonization, renewable energy

Around 2000, the Company began establishing a series of offshore bases and expanding sales channels around the world. In preparation for the development of next-generation products and the expansion of the semiconductor market, the Company completed the construction of the new Sanda Factory in 2020.

In 2022, when the Company's shares were moved from the First Section of the Tokyo Stock Exchange to the Prime Market, both sales and operating income reached record highs for the second consecutive year. The Company continues to transform its business and organizational structure with the aim of further enhancing corporate value. The Company remains focused on the development of new materials and technologies that will take the lead in the next generation.

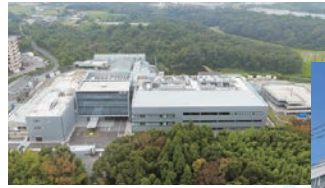

Construction of the new Sanda Factory (2020)



Tanken Seal Seiko Co., Ltd. is acquired as a member of the Group. (2023)

Electronic Equipment Business

¥36,819 million  
75.6%

Industrial Equipment Business

¥11,844 million  
24.3%

FY2022 sales  
¥48,702 million

(100 millions of yen)  
600

2024 100th anniversary

400

2022 The Company's shares are moved to the Prime Market of the Tokyo Stock Exchange.

2012 Production of a new type of rotary joint for the semiconductor market begins.

2004 The Kyushu Factory is completed.

2001 The Company's shares are listed on the First Sections of the Tokyo Stock Exchange and Osaka Securities Exchange.

200

0

1990

2000

2010

2020

2022

2024

2025 (FY)

1991 Collapse of the Japanese economic bubble; Collapse of the Soviet Union  
1993 Establishment of the European Union  
1999 Creation of the Euro

2005 Kyoto Protocol comes into effect.  
2008 Lehman Shock

2011 Great East Japan Earthquake  
2016 Paris Agreement comes into effect.

2020 Brexit comes into effect.  
COVID-19 pandemic  
2021 The Tokyo Olympic and Paralympic Games are held.

# Manufacturing Capital Supports Growth

## Establishing technological, development, and production systems through timely capital investments

By renovating the Sanda Factory and constructing the Fukuchiyama Second Factory and the Sanda Innovation Center, we are renewing our production system and constructing systems designed to increase production; moreover, we are strengthening our engineering and development divisions and enhancing our training facilities. In addition, as we construct new factories, we are incorporating environment-friendly solutions such as the Comprehensive Assessment System for Built Environment Efficiency (CASBEE).



### Strengths

1

## A Mother Factory That Provides Fluid Control Technology

As our main factory, the Sanda Factory plays the role of a mother factory. It is responsible for producing sealing products for the industrial equipment market. These products include mechanical seals, gland packings, and gaskets. The factory also incorporates a research and development department.

In March 2020, the factory was reopened as a state-of-the-art factory following extensive renovation work intended to improve productivity through a rationalized layout; expanded automation and mechanization; and the introduction of IoT. As part of this renovation, efforts were made to improve the working environment and safety; to implement a business

continuity plan; and to improve visitors' sense of trust and security through the addition of a technology training center, analysis center, and showroom.

Looking to research and development, the Innovation Center, which will bring together engineers from the Sanda Factory, is scheduled to be completed in October 2023. We intend to strengthen our product development capabilities by combining, fusing, and integrating technologies across our organization. Furthermore, with an eye to markets of the future, we will promote initiatives targeting advanced technologies by strengthening collaboration among industry, government, and academia while focusing on the pursuit of innovations.

### Strengths

2

## An Agile Global Production System That Responds Quickly to Emerging Market Trends

### Expanding production facilities to meet shifting demand

In order to respond to the ongoing increase in demand for products in the electronic equipment market, we are building the Fukuchiyama Second Factory. The factory is intended to increase production capacity by up to 80%; strengthen cost competitiveness through the construction of a new production system; comply with customers' stringent quality requirements; and highlight our technology through its open concept design. It features an expansion zone capable of accommodating three more factories of the same size. We plan to use this space to expand our production capacity with a flexible approach.

Moreover, this factory features an environment-friendly design, as it will incorporate solar power generation and energy-efficient equipment.



Fukuchiyama Second Factory

### Maintaining local production systems outside Japan

We are strengthening our facilities in the U.S.A. and China, where the market for products in the electronic equipment business segment is expected to expand. In the United States, we have set up a simple laboratory at our Fremont Office to accommodate the development needs of semiconductor equipment manufacturers. We also intend to expand the warehouse space to meet growing demand.

In China, Pillar Technology (Chuzhou) Co., Ltd. has adopted the model of local production for local consumption in response to the demand for products for the electronic equipment market. By increasing the number of items produced and strengthening its production system, it is expanding its product lines as well as the quantities produced.



Pillar Technology  
(Chuzhou) Co., Ltd.

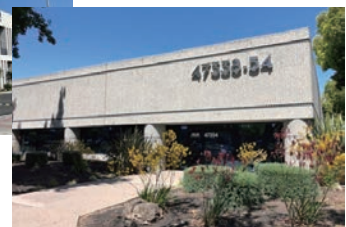

Nippon Pillar Corporation of America,  
Fremont Office

### Promoting automation and the adoption of IoT

The Sanda Factory has introduced innovations such as automated guided vehicles (AGVs), automated guided forklifts (AGFs), radio frequency identification (RFID), and management systems employing short-range wireless communication with IC tags.

By utilizing these improvements, we aim not only to reduce work loads but also to eliminate human error, reduce walking distances, and improve productivity while minimizing lead times through unmanned operation.

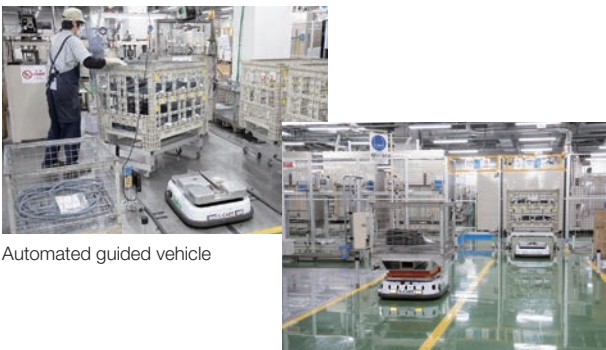

Automated guided vehicle

### High-standard clean room

At the Fukuchiyama Factory, we have introduced a large-scale industrial clean room, which is a space intended to minimize airborne microparticles and microorganisms to a level of cleanliness that attains a specific standard in order to prevent contamination of surfaces with impurities and dust.

Even fine dust remaining on the surface of electronic components presents a risk of malfunction. It is therefore extremely important to eliminate dust and other fine particles by employing high-performance filters and by eliminating static electricity. We will continue to meet the future needs of the market by equipping our facilities with clean rooms to meet the highest standards.

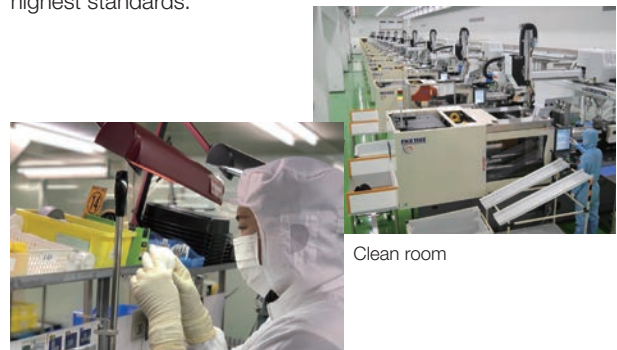

Clean room

### A facility that enhances the peace of mind and security of visitors

The technology training center at the Sanda Factory has prepared training programs not only for our employees, but also for our sales partners and partner companies. We have provided samples of pumps, valves, and other machines that enable visitors to expand their knowledge of our products through hands-on training while learning how to incorporate them in their operations.

Our showroom is also available for customers who visit our factory. Here, they can gain more detailed information about our Company. We have also designed visual presentations for greater ease of understanding. By introducing applications in which our products are actually used as well as cutaway displays that clarify the structure of our products, we are creating opportunities for greater business development.



Technology training center

Showroom

### Safe and environment-friendly design

As a safety measure against earthquakes, we have adopted seismic isolators of our own design at the new Sanda Factory, Fukuchiyama Factory, and Kyushu Factory.

We are also working to obtain certification under the Comprehensive Assessment System for Built Environment Efficiency (CASBEE) for our environment-friendly designs. Both the new Sanda Factory and the Sanda Innovation Center have acquired CASBEE-A certification, while the Fukuchiyama Second Factory has applied for CASBEE certification.

In addition to acquiring these CASBEE certifications, we are adopting eco-friendly measures such as low-carbon enzymatic construction material (ECM) concrete and cubicles incorporating soybean oil.



Seismic isolator / Slide bearing

Sanda Factory

## R&D

Nippon Pillar Packing will create new value by upgrading our core technologies and strengthening our fundamental technologies based on the principles of CLEAN, SAFETY, and FRONTIER.



### Nippon Pillar Packing's Core Technologies and R&D Concepts

Since our founding, we have utilized fluid control technology and material development to explore unknown materials and research and develop the latest technologies.

Research and development is based on our fundamental technologies such as seals, material engineering, mechanical engineering, injection molding, analysis, and mold design, which result in upgraded core technologies held by our electronic equipment business and industrial equipment business. Core technologies in the electronic equipment business include resin seals, fluorocarbon resin injection molding, microscopic analysis, and computer aided engineering (CAE), which are mainly used to develop products for the

semiconductor market, which has high cleanliness requirements. The core technologies in the industrial equipment business are tribology, material formulation, and CAE, which are mainly used to develop products for the electric power and petrochemical markets. Core technologies upgraded in each business are shared through personnel rotations across the businesses, promoting efforts to create new value through the combination of core technologies and accelerate the advancement of core technologies. We are also making efforts through industry-government-academia collaboration by dispatching engineers to universities as part of measures to train future engineers and strengthen our fundamental technologies.

### Analysis and Testing Equipment

As the owner of many patented products, we conduct a number of experiments under actual operating conditions before introducing our products to society. Our research and development, supported by the latest verification technologies, continues to evolve toward even higher goals.



#### Microscopic analysis technology

In order to meet the increasingly stringent cleanliness requirements associated with the miniaturization of semiconductors, we are building a system capable of multifaceted analysis (both inorganic and organic).

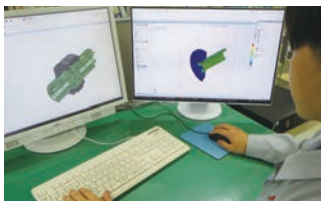

#### Design with 3D CAD

We perform basic structural analysis and design seamlessly, leading to faster product design and proposals.



#### Test equipment for semiconductor and liquid crystal manufacturing devices

To evaluate performance under severe operating conditions in the semiconductor market, we have thermal cycle test equipment capable of cycling through high and low temperatures.



#### Data collection and analysis test equipment for failure prediction

This test equipment is used to collect and analyze data on pressure, temperature, torque, vibration, etc. under operating conditions, including failure modes, in order to establish technology for predicting mechanical seal failures.



#### Low temperature test equipment for valves

This test equipment is used to collect data on sealing characteristics, sliding characteristics, and stress relaxation characteristics of gland packing for valves in low temperature environments (-150 to 0°C). It is utilized for the development of gland packing suitable for low-temperature environments.



#### 1000kN universal testing equipment

The device is capable of performing sealing, compression, and tensile tests while precisely controlling the load on products and materials. With 24-hour continuous operation possible, continuous data can be obtained on changes that occur over time.

## Innovation through Industry-Government-Academia Collaboration

We are engaged in research on diamond coating as one of the ways to improve materials technology through industry-government-academia collaboration. Diamond is a material with a variety of excellent properties, and its use as a sliding material in mechanical seals can dramatically improve sliding properties, especially in high-load applications. In the mature sealing field, one of our approaches to dramatically improve product performance is to identify the relationship between the physical properties of diamond films and sliding properties and explore deposition technologies that form ideal diamond films.

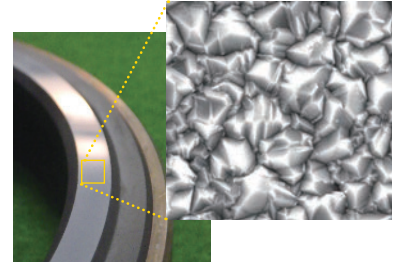

Diamond coating

## Efforts Aimed at the Semiconductor Market

Accompanying the miniaturization of semiconductors, particle reduction demands are increasing year by year, and there is a need to improve the cleanliness of individual components. In order to suppress particle occurrence and improve particle emission performance, we are promoting front-loaded development to identify and solve problems in the initial development stage by combining our basic data with CAE and testing hypotheses through verification tests, such as the development of a series of sweep fittings with a smooth flow path and piping design and pump wetted part design with consideration of pressure loss and liquid displacement. In addition, for cleanliness, we are building microscopic analysis technology to assess the current conditions and to check the state of further cleanliness solutions.



Super 300 Type Pillar Fitting Sweep Elbow

## Efforts Toward a Carbon-Neutral Market

As decarbonization of society progresses and diverse efforts are being made around the world, we are developing products based on the fundamental technologies we have cultivated in fluid control, material technologies, and resin molding. In product development for the hydrogen market, which is expected to become a next-generation energy source, we are restructuring our in-house evaluation equipment. As one of these efforts, we will install testing equipment and analytical instruments that enable evaluations in a hydrogen atmosphere to expand our knowledge of tribochemical reactions in sliding parts and create new value that meets the needs of the market. We are also developing products for the automotive industry, which is undergoing a major transformation from fossil fuels to EVs and FCVs.



Friction and wear test equipment in a hydrogen atmosphere

### Utilizing DX

## Promoting a Digital Transformation through the Fusion of Deduction and Induction

As one example of the utilization of a digital transformation, we are working on the automation of visual inspections of injection molded products (fluorocarbon resin products).

We are focused on building an imaging environment suitable for our products and update the accumulated data of good and defective products through AI learning, thereby eliminating the need for human resources in the inspection process and saving manpower.

By combining the technical elements of a digital transformation (the inductive method) with existing engineering simulations (the deductive method), such as structural analysis and thermal/fluid analysis, it is possible to perform coupled analysis of complex physical phenomena with high accuracy and speed, previously considered to be difficult. This enables us to clearly set specifications that can be compatible with multiple target specifications in the early stages of development, and we are also working to achieve a design and development process (front-loading) with no backtracking.

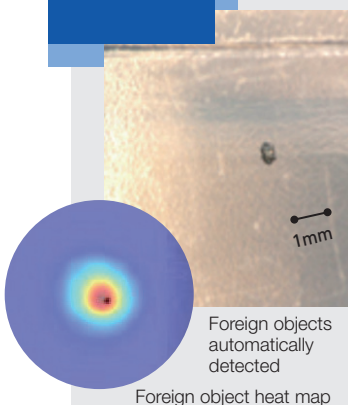

Foreign objects automatically detected

Foreign object heat map

## Serving as a Bridge of Technology in the Global Field

In 1980, the Group established Korea Pillar Packing Co., Ltd. as its first overseas base of operations, and has since been making strides toward globalization.

Currently, we are operating in 11 countries and regions around the world.

Going forward, we will continue to strengthen and expand our overseas network and provide high-performance products that benefit the lives of people around the world.

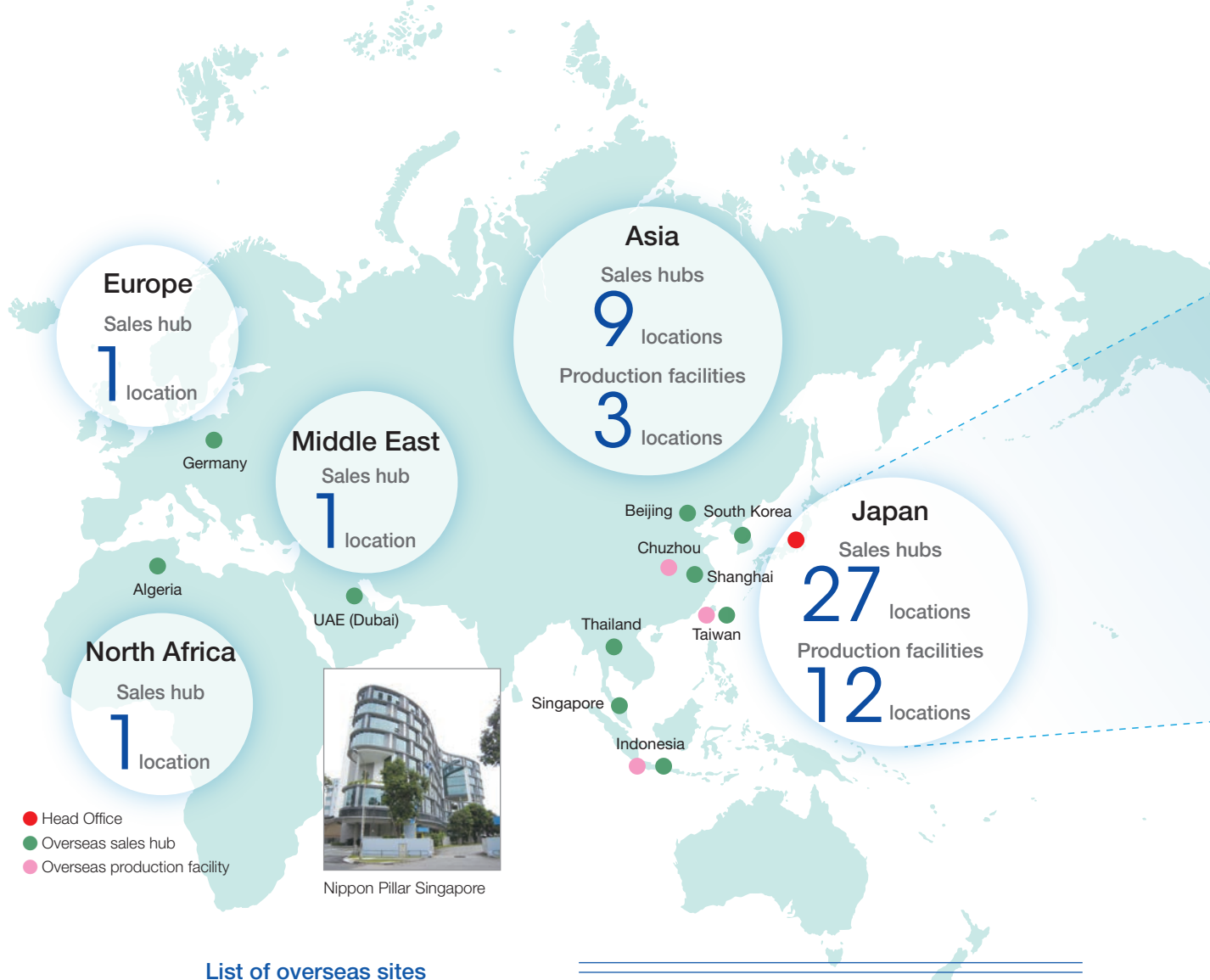

### List of overseas sites

Nippon Pillar Singapore Pte Ltd.  
PT. Nippon Pillar Manufacturing Indonesia  
PT. Nippon Pillar Indonesia  
Nippon Pillar (Thailand) CO., Ltd.  
Taiwan Pillar Industry Co., Ltd. Taipei Office  
Taiwan Pillar Industry Co., Ltd. Takao Factory  
Pillar Technology (Chuzhou) Co., Ltd.

Shanghai Pillar Trading Co., Ltd.  
Shanghai Pillar Trading Co., Ltd. Beijing Office  
Korea Pillar Packing Co., Ltd.  
Nippon Pillar Middle East FZCO  
Nippon Pillar Corporation of America Houston Office  
Nippon Pillar Corporation of America Fremont Office  
NPK Fluid Control Systems Mexico S.A. de C.V.  
Nippon Pillar Europe GmbH

### History of our expansion into markets outside Japan

1980	Korea Pillar Packing Co., Ltd. is established.	2007	Shanghai Pillar Trading Co., Ltd. in China is established.
1993	Nippon Pillar Singapore Pte Ltd. as a sales hub for Southeast Asia is established.	2010	Nippon Pillar Packing Co., Ltd. Alger Liaison Office in Algeria is established.
1999	Nippon Pillar Corporation of America in the U.S.A. is established.	2015	Nippon Pillar Middle East FZCO in the UAE is established.
2001	Taiwan Pillar Industry Co., Ltd. in Taiwan is established.		Nippon Pillar (Thailand) Co., Ltd. in Thailand is established.
2003	Suzhou Pillar Industry Co., Ltd. in China is established.		





Fukuchiyama Factory

- Head Office
- Factory, business location, branch office
- Group companies

Kobe Branch Office

Hiroshima Branch Office

**Kyushu Factory**

Kyushu Branch Office

**Fukuchiyama Factory**

Kyoto Branch Office

Tokyo Branch Office

Yokohama Branch Office

Nagoya Branch Office

Osaka Branch Office

**Sanda Factory**



Nippon Pillar Corporation of America

U.S.A. (Fremont) (Houston)

Mexico



NPK Fluid Control Systems Mexico

**North and Latin America**

Sales hubs

**2** locations

Production facilities

**2** locations



Sanda Factory



Kyushu Factory

**List of domestic sites**

〈Factories and business locations〉

- Sanda Factory (Sanda City, Hyogo Prefecture)
- Fukuchiyama Factory (Fukuchiyama City, Kyoto Prefecture)
- Kyushu Factory (Koshi City, Kumamoto Prefecture)

〈Branch offices〉

- Tokyo Branch Office
- Yokohama Branch Office
- Nagoya Branch Office
- Kyoto Branch Office
- Osaka Branch Office
- Kobe Branch Office
- Hiroshima Branch Office
- Kyushu Branch Office

〈Domestic Group companies〉

- Pillar Seal Solutions Co., Ltd.
- NP Real Estate Co., Ltd.
- NIPPON PILLAR PRECISION MFG. CO., LTD.
- NP Kogyo Co., Ltd.
- Nippon Pillar Kyushu Co., Ltd.
- Masuko Manufacturing Co., Ltd.
- TANKEN SEAL SEIKO CO., LTD.

- 2016 NPK Fluid Control Systems Mexico S.A. de C.V. in Mexico is established.
- 2018 Nippon Pillar Europe GmbH in Germany is established.
- 2019 PT. Nippon Pillar Manufacturing Indonesia and PT. Nippon Pillar Indonesia in Indonesia are established. A production facility in Nippon Pillar Corporation of America Houston Office is added.

- 2020 Pillar Technology (Chuzhou) Co., Ltd. in China is established.
- 2021 Operation of Pillar Technology (Chuzhou) Co., Ltd. begins.
- 2023 Beijing Office of Shanghai Pillar Trading Co., Ltd. opens.

# Electronic Equipment Business

Expanding our production bases to meet growing demand for semiconductors while focusing on recycling in response to resin shortages

We aim to respond to the ever-growing semiconductor market by ensuring stability of supply, a challenge we are addressing by expanding our production bases in Japan and in other markets. Furthermore, we are promoting the use of substitute and recycled materials in response to the shortage of fluororesin. We also intend to improve the cleanliness of recycled resins.



## Business Overview and Market Environment

As part of our business, we manufacture fluororesin fittings and pumps for semiconductors and LCDs. Amid dizzying changes in the market environment, such as the spread of the COVID-19 pandemic, the war in Ukraine, and friction between the U.S.A. and China, the semiconductor market continues to face a shortage of semiconductors due to increased global demand. Consequently, our performance in fiscal 2022 exceeded that of fiscal 2021, which was a successful year. On the other hand, fiscal 2022 was also a year in which we faced the major challenge presented by the shortage of fluororesin as a raw material. As countermeasures, we considered recycling resins that had previously been discarded as scrap and using alternative materials suited to specific applications. In addition, since these products must meet semiconductor specifications that require a high level of

cleanliness, we worked with our customers to confirm suitability for the application at hand during the switch to recycled and alternate materials. At the same time, we worked hard to secure the required supply volume through tenacious negotiations with resin manufacturers.

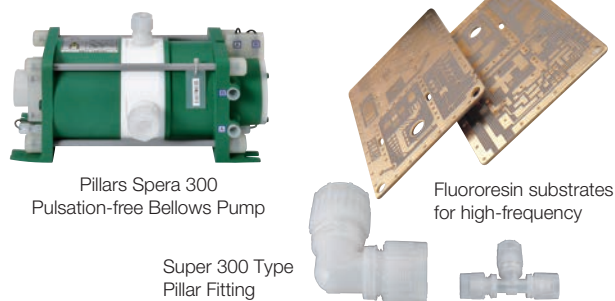

## Review of “BTvision22,” Our Previous Medium-Term Management Plan

Fiscal 2022 marked the final year of “BTvision22,” our previous medium-term management plan. The fiscal year concluded with net sales increasing by 6.4 billion yen, representing an increase of 21.1% compared to the preceding fiscal year, thus setting a record high for the second consecutive year. While strong demand for semiconductors in the IT and automotive sectors provided a significant tailwind, I feel that the various measures we implemented to ensure adequate supply greatly underpinned these results. For example, in terms of capital investment, we have implemented equipment investment plans that look ahead several years, considering the fact that manufacturing equipment often entails lengthy delivery times. In the area of injection molds, our Group acquired Masuko Manufacturing Co., Ltd., a manufacturer specializing in molds, in fiscal 2022. As a result, we were able to introduce many molds by sharing and collaborating with the company in a detailed and timely manner. In addition,

we have been able to pass on price increases attributable to soaring raw material prices, but we recognize that this required gaining the understanding of our customers, an accomplishment that reflected their deep trust in our products.

■ Sales trend graph

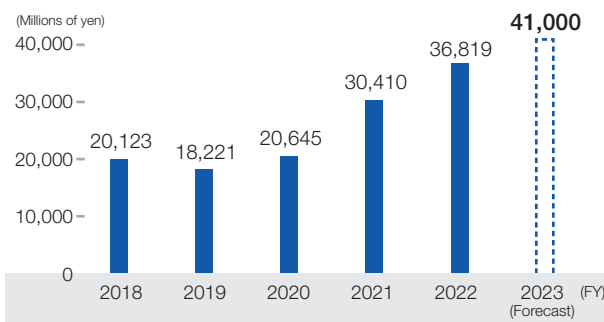

## Outlook for “One2025,” Our New Medium-Term Management Plan

Under our new medium-term management plan titled “One 2025,” scheduled for introduction in fiscal 2023, we aim to establish a solid business foundation by continuously introducing high-value-added and differentiated products to the growing and continuously evolving semiconductor market.

We will continue to strengthen our foundation by increasing our product supply volumes and improving productivity with the start of operations at the Fukuchiyama Second Factory. At the same time, we will increase our competitiveness in terms of cost and delivery schedule.

In addition, in the Chinese market, Pillar Technology

(Chuzhou) Co., Ltd., will seek to increase its market share by expanding its production capabilities. Meanwhile, in the European and American markets, we aim to further increase adoption of our products among semiconductor equipment manufacturers.

As for the challenges we intend to take on, we will strive to realize the vision of “One2025” by building a resilient supply chain and promoting resin recycling. We will also introduce two-color moldings that combine two types of resins as well as large-scale moldings, two challenges that we have not previously attempted.

## Future Tasks and Goals

The semiconductor market is expected to plateau in fiscal 2023, but expectations are high that the next wave of market demand will arrive in the second half of 2023 and in 2024. As for overall market trends, we expect the semiconductor market to continue growing, driven by demand in the IT and ICT sectors and in the automotive industry. In addition, the evolution of communications technologies such as 5G and 6G in the information and communication market will drive demand not only for

semiconductors but also for our fluoro resin substrates (high-frequency substrates). We will also promote the development of non-semiconductors that take advantage of the characteristics of fluoro resin.

As we approach our 100th anniversary in 2024, we will continue to promote the forward leap embodied in “One 2025” as we embark on our next 100 years while valuing our founding spirit as a company that excels at handling fluid control components.

## TOPICS

### Utilizing Recycled Resins

As a measure to address the shortage of fluoro resin, we are reusing scrap resin generated after molding as recycled resin. Due to the risk of contamination, we are currently in consultation with customers and limiting the scope of application of this material. In the future, we will focus on improving its cleanliness in order to contribute to the efficient use of limited resources as well as waste reduction.



Nuts made of recycled materials (left)

### Pillar Technology (Chuzhou) Co., Ltd., has begun manufacturing products for use in semiconductor manufacturing equipment.

In response to efforts to strengthen our semiconductor business in China, Pillar Technology (Chuzhou) Co., Ltd. has undertaken full-scale manufacturing of products for use in semiconductor manufacturing equipment. We also opened a new office in Beijing, where many semiconductor-related companies have congregated. In order to respond to the future needs of the Chinese semiconductor market, which is expected to continue expanding, we will promote the practice of local production for local consumption.



Clean room at Pillar Technology (Chuzhou) Co., Ltd.

# Industrial Equipment Business

## Establishing a new business foundation during the major shift toward carbon neutrality

In order to contribute to the emergence of a decarbonized society, we will consolidate the Group's technologies and expand our business through R&D initiatives utilizing our Innovation Center and synergies with Tanken Seal Seiko.



### Business Overview and Market Environment

Our business deals mainly with the key industries that drive the Japanese economy, including electric power, petrochemicals, and shipbuilding. These industries are implementing carbon-neutrality initiatives and are thus immersed in a period of major transition. They are now promoting non-fossil-fuel energy sources, a structural transformation of their respective industries, and significant energy-efficiency initiatives. We are therefore focusing on creating business opportunities as well. The Japanese government's carbon-neutrality policy has been a major driving force, and as each company undergoes various verifications and demonstrations, we are encountering opportunities for our products to be evaluated. Looking to the market for next-generation batteries, hydrogen as a fuel, and electric vehicles (EVs), we are expecting commercial operation and mass production to come to the fore in the next three to five years. I am confident that fiscal 2022 has marked a step toward establishing our business in new growth markets.

On the other hand, the semiconductor shortage and the emergence of global economic disruptions have had an impact; parts procurement has been affected by longer delivery times and higher prices. In order to maintain a sustainable supply system, we have been negotiating and coordinating with our customers to an unprecedented extent. This has involved proposing substitutions, suggesting design changes, and solving problems in close collaboration with our customers.



### Review of "BTvision22," Our Previous Medium-Term Management Plan

Since we launched our previous medium-term management plan, "BTvision22," in fiscal 2020 during the emergence of the COVID-19 pandemic, our plans were impacted by changes in the economic environment in which we operate. Due to the decline in new plant projects and the extension or contraction of scheduled repairs at existing plants, both new demand and maintenance demand in the electric power and petrochemical industries have declined. On the other hand, products for precision equipment for the semiconductor market performed well, contributing to the improvement in sales and profits for the business as a whole. Until recently, most of the demand for these products had arisen from within Japan but, as our customer base has grown, demand from outside Japan has increased. As a result, net sales in

fiscal 2022, the final year of "BTvision22," grew by 1.7 billion yen, representing a year-on-year increase of 16.7% and a new record high.

#### Sales trend graph

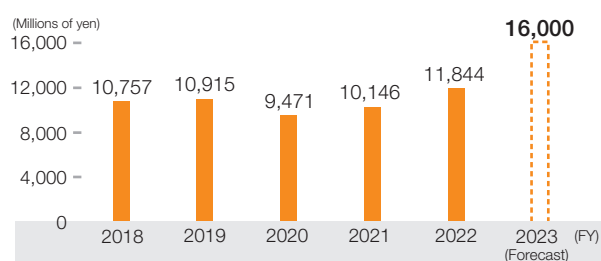

---

---

## Outlook for “One2025,” Our New Medium-Term Management Plan

---

---

Under “One2025,” our new medium-term management plan scheduled for implementation in fiscal 2023, we will adopt a range of measures with the goal of acquiring an overwhelming share of new global markets created by the response to social issues arising from decarbonization.

For example, in fiscal 2022, we established a new team of specialists to address digital transformation within the engineering division as a response to the increasing digitization taking place across society. In April 2023, our Group acquired Tanken Seal Seiko Co., Ltd., thereby adding a new product group and material technology. This fall, construction of the Innovation Center in our Sanda Factory will be completed, which will consolidate the Group’s technologies and promote development of technologies and products through collaboration among industry, government, academia, and our Group’s own companies. As the industrial structure shifts toward the emergence of a decarbonized society,

we will take advantage of these new initiatives to establish innovative businesses that contribute solutions to social issues. We will do so by making full use of our technological expertise, ability to devise solutions, and capabilities as a comprehensive manufacturer of fluid control equipment.

In addition, as the oil refining and electric power industries experience generational turnover among skilled employees, and as younger maintenance personnel enter the workplace, demand has been growing for maintenance-related consulting services such as advice on how to install seals. We intend to expand the functions of our repair bases and utilize both internal and external resources to increase customer contact by holding workshops and providing on-site guidance. We will expand our maintenance business and expand our stand-alone sales business to encompass services with the goal of expanding sales and improving our profitability.

---

---

## Future Tasks and Goals

---

---

Look to our existing markets and product lines, we plan to develop seals for precision equipment used in the market for next-generation semiconductors, which must meet even more stringent requirements. Through this endeavor, we intend to expand our global market share with gland packings that comply with international standards.

For the emerging carbon-neutral market, we aim to establish a strong business foundation as we move to the next stage of commercialization and mass production.

In terms of our supply system, we feel that providing

customers with peace of mind is essential. We intend to achieve this by supplying products in a stable and sustainable manner while providing solutions for the risks that exist.

Our core competency, fluid control technology, is directly linked to the need to address environmental and social issues related to the decarbonization of society. As we approach our Company’s centennial celebration, we are seeking to return to the origins of our founding and continue to be an entity the world relies on.

### TOPICS

Sample system

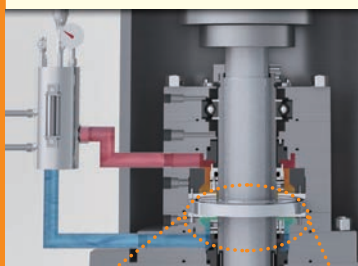

### Market Launch of the Pillar Sealant Circulating & Cooling System (PSCC)

The Pillar Sealant Circulating & Cooling System (PSCC) represents a new concept for a sealant circulation system equipped with a pumping function in the mechanical seal unit.

Until recently, mechanical seals for agitators have required an auxiliary device, called a pressure unit, in the high-temperature range where the internal temperature can exceed 200°C when water or solvents are used as the sealing liquid (or lubricating liquid). Pressure units are associated with several issues, such as the high cost of installing equipment for customers and the need for careful consideration of the installation location. The PSCC, however, can be operated by the seal unit alone by incorporating a pump function into the mechanical seal, eliminating the need to install a separate pressure unit. In addition to forming an appropriate sealing environment, this innovation contributes to reduced running costs and space requirements. What’s more, the pump can be repaired, contributing to energy efficiency and resource conservation. In addition, a simplified system configuration is possible, eliminating the need for complicated operations. We will continue to develop products that contribute solutions to environmental and social issues while addressing customer issues.

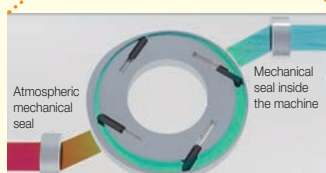

Illustration of pump section

## ISO Certification and IATF Certification

Under its quality-first approach, the Group has obtained both ISO9001 and IATF certification.

### ISO Certification

In 1995, the Group became the first domestic seal manufacturer to obtain ISO9001 certification for its quality management system. The current certifying body is the Japan Quality Assurance Organization, while accreditation is provided by JAB (in Japan) and UKAS (the UK). (The head office and the Sanda and Fukuchiyama Factories have obtained ISO 9001 certification.)



### Non-Use of Asbestos

Our products do not use asbestos.

### IATF Certification

In 2019, products for automotive use produced at the following factory have obtained IATF16949 certification, an international quality management system standard for the automobile industry. IATF16949 was developed by Western automobile manufacturers and automobile industry-related organizations to prevent defects, reduce inconsistency and waste in the supply chain, and bring about continuous improvement by standardizing requirements for parts manufacturers. Based on ISO9001, this quality management system incorporates a large number of unique requirements.



IATF Certificate No.0363056

Registered site: Nippon Pillar Packing Co., Ltd. Sanda Factory  
Scope of certification: Design and manufacturing of gaskets, packing, exhaust system molded products, and fluorocarbon resin substrate

## ESG-Related External Assessments

We have been assessed by an externally based ESG evaluation organization and have been selected as a member of the ESG Index.



FTSE Blossom Japan Sector Relative Index

## ESG/SDGs Assessment Loan

In the ESG/SDG Assessment Loan by Sumitomo Mitsui Banking Corporation, the Company was judged as having implemented excellent ESG initiatives and information disclosure in its corporate management, including response to climate change, initiatives in environmentally friendly products and services, and consideration for suppliers, and as being highly motivated to contribute to the achievement of the SDGs through our business operations.



## Won the Plunkett Award

Our Pilaflon™ products, Super type fitting gained global recognition and the Company has won the DuPont Plunkett Award three times.



## Participated in International Exhibitions



### Valve World Expo

We exhibit our products at the Valve World Expo, a global trade fair for valve products and technologies.

### SEMICON Japan

SEMICON Japan is a general exhibition for worldwide semiconductor-related industries. We publicize our products and also take the opportunity to gather the latest information.



## Company Profile (As of March 31, 2023)

Company name	Nippon Pillar Packing Co., Ltd.
Head Office address	7-1, Shinmachi 1-chome, Nishi-ku, Osaka 550-0013, Japan
Establishment	1924
Representative	President Yoshinobu Iwanami
Capital	¥4,966 million
Listed stock exchange	Tokyo Stock Exchange Prime Market
Number of employees	867 (consolidated)
Main products	Pilafion™ products (fluorocarbon polymers products), mechanical seal products, gland packings and gasket products
URL	<a href="https://www.pillar.co.jp/en/">https://www.pillar.co.jp/en/</a>

## Nippon Pillar Packing by the Numbers

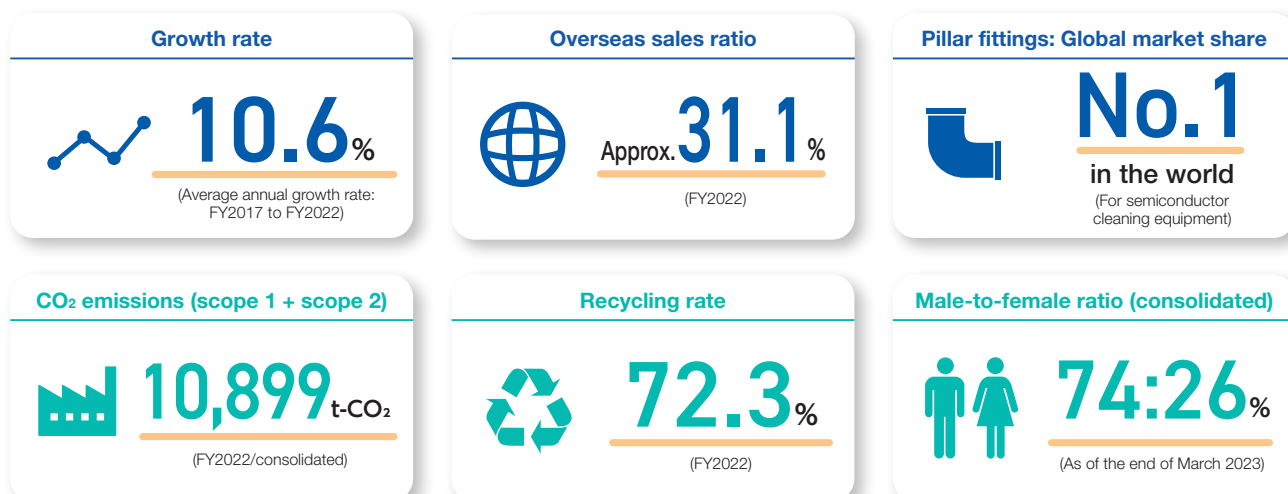

## Business Performance

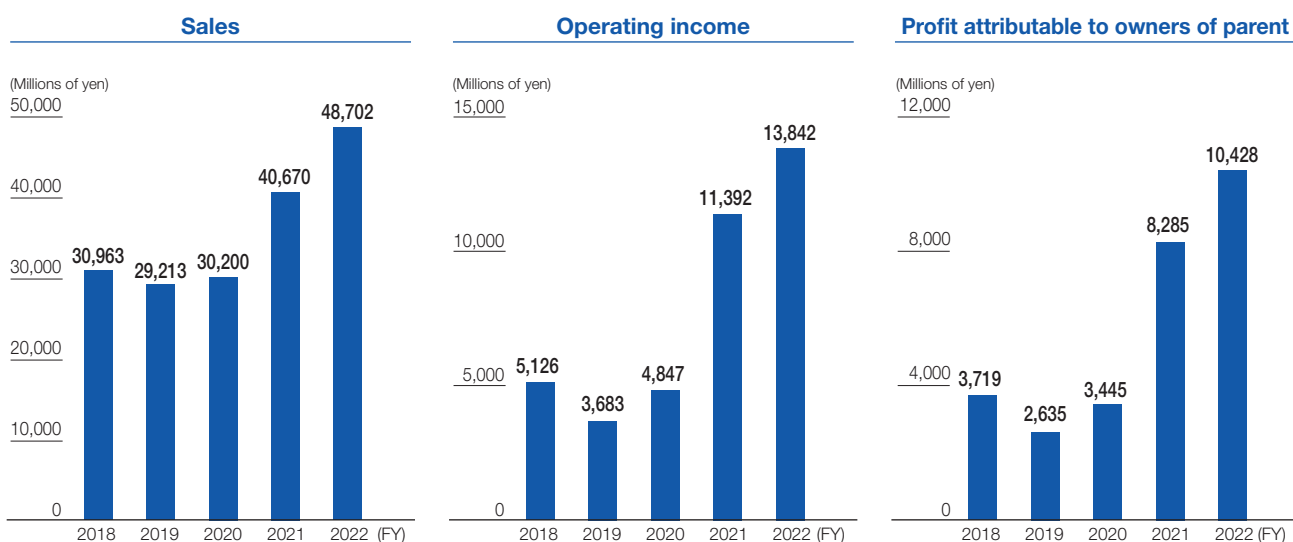



**NIPPON PILLAR PACKING CO., LTD.**

7-1, Shinmachi 1-chome, Nishi-ku, Osaka 550-0013, Japan  
<https://www.pillar.co.jp/en/>